

Audi A3

Current Flow Diagram

No. 4 / 8

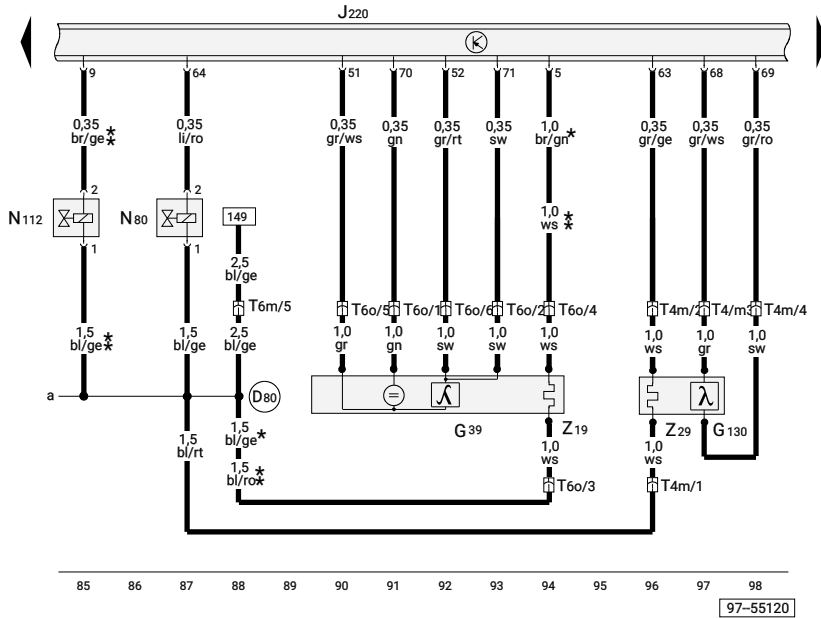
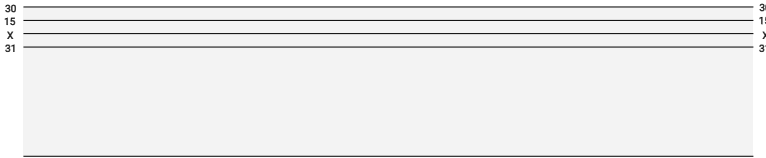

Motronic control unit, lambda probes, solenoid valves

- G39 - Lambda probe
- G130 - Lambda probe downstream of catalytic converter
- J220 - Motronic control unit
- N80 - Activated charcoal filter system solenoid valve 1 (pulsed)
- N112 - Secondary air inlet valve
- T4m - 4-pin connector, lambda probe, in engine compartment, right
- T6m - 6-pin connector, brown, in plenum chamber
- T6o - 6-pin connector, lambda probe, in engine compartment, right
- Z19 - Lambda probe heater
- Z29 - Lambda probe 1 heater, downstream of catalytic converter
- D80 - Positive (+) connection (87a - for activated charcoal filter system solenoid valve), in engine compartment wiring harness



- ws = white
- sw = black
- ro = red
- br = brown
- gn = green
- bl = blue
- gr = grey *
- li = purple
- ge = yellow
- or = orange
- rs = pink

**

- Only applies to models with engine code BAM
- Only applies to models with engine codes ARY, ARX, AUM, AUQ