



Audi Q7 - Running Gear

Self-Study Programme 362

With the Q7 Audi offers a vehicle that marks a superlative new development in the sport utility vehicle (SUV) segment. The Audi Q7 ingeniously combines sportiness and versatility, sophisticated technology and the luxury of a premium-class vehicle. On the road it excels with the driving performance and dynamism of a sports car; off-road it redefines the benchmark in its category. The chassis of the Audi Q7 also excels with its all-round qualities.

Steel-spring suspension and twin-tube shock absorbers are designed for sporty driving and superior comfort, even off-road. Also available on request: adaptive air suspension. The combination of air suspension and an electronically controlled damping system represents the perfect synthesis of decidedly sporty handling and supreme ride comfort.



Contents

Introduction

Overview	4
----------------	---

Front axle

Overview	5
----------------	---

Rear suspension

Overview	6
----------------	---

Brake system

Overview	7
Foot-operated handbrake	8
The active brake servo	12

ESP

Overview	17
Functions in overview / New functions	18
System components	24
Service work	26

Steering / wheels and tyres

Overview	27
Wheels overview / tyre pressure check system	28

adaptive air suspension (aas)

Overview	29
System components	32
Vehicle ride heights / modes	38
Control response	41
Operation and displays	42
Service work	47

This Self-Study Programme teaches the design and function of new vehicle models, new automotive components or new technologies.

**The self-study programme is not a workshop manual!
All values given are intended as a guideline only, and refer
to the software version valid at the time of publication of the SSP.**

Please refer to the relevant service literature for current inspection, adjustment and repair instructions.

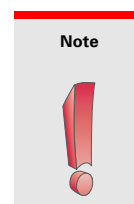
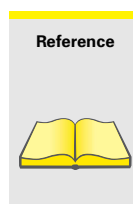

Introduction

Overview

The Audi Q7 is offered with a conventional steel-spring suspension; air spring suspension (aas) is optional. aas is standard equipment for the V10 TDI.

Tire mobility system (TMS) as standard equipment, optional folding wheel or 18" spare wheel

Double wishbone rear axle with split upper wishbones

18" wheels as standard equipment; 18"-20" wheels are optional

ESP MK25E1 with active brake servo

Double wishbone front axle

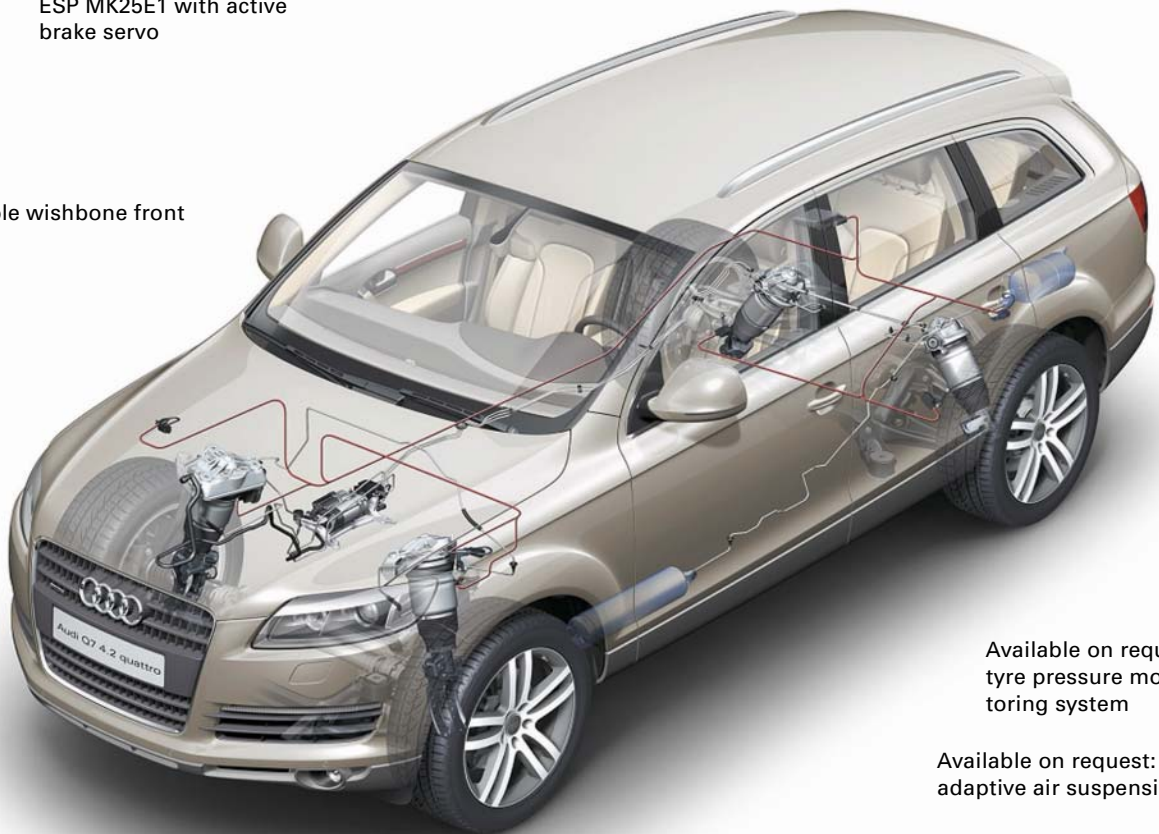

Available on request: tyre pressure monitoring system

Available on request: adaptive air suspension

Foot-operated handbrake

Ventilated 17" and 18" disc brakes front and rear

Hydraulic rack and pinion steering with Servotronic function as standard

Manually adjustable and electrically lockable steering column; electrical adjustment is optional

362_001

Overview

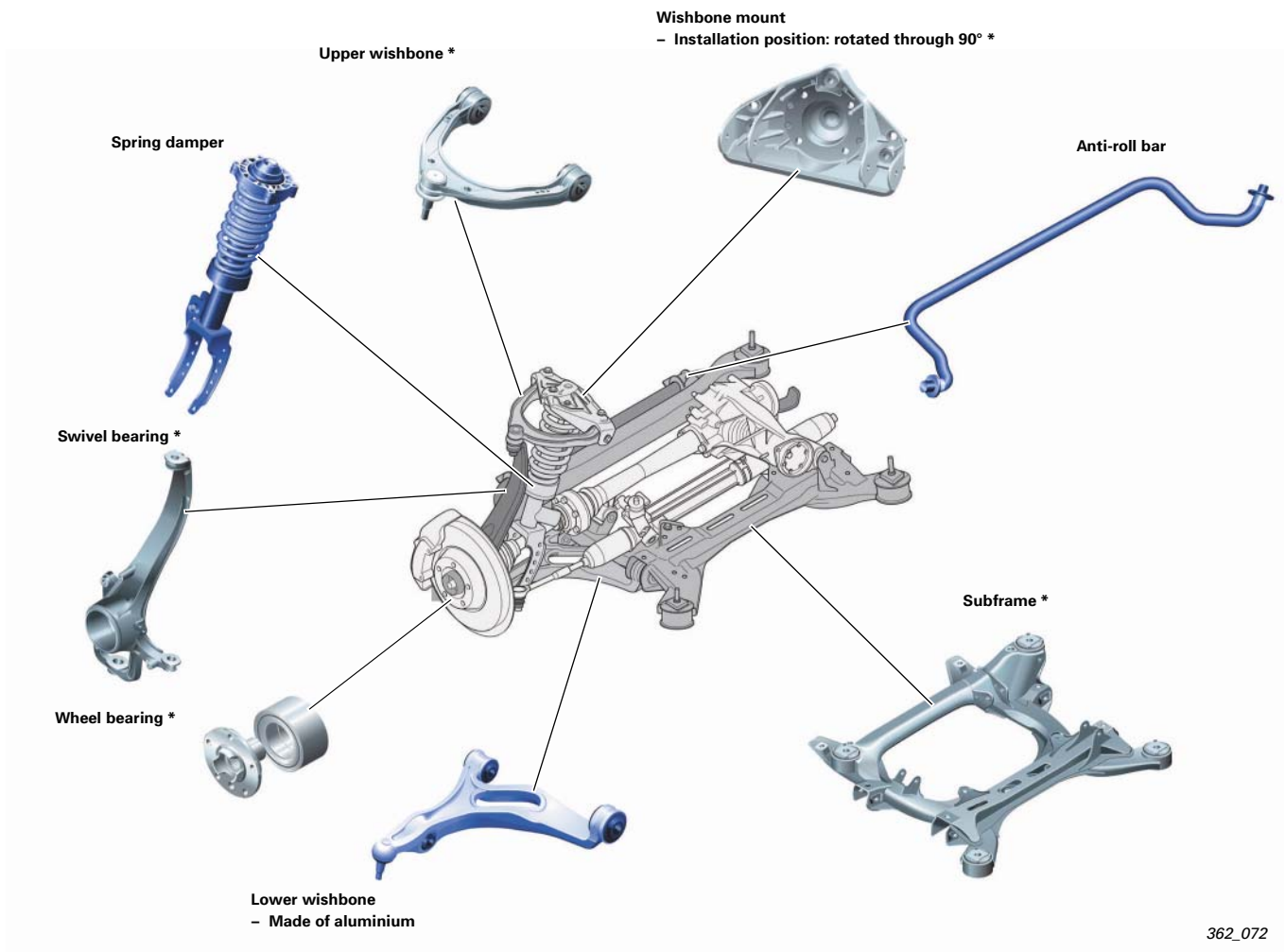

362_072

All parts marked * are common parts used in the VW Touareg

Rear suspension

Overview

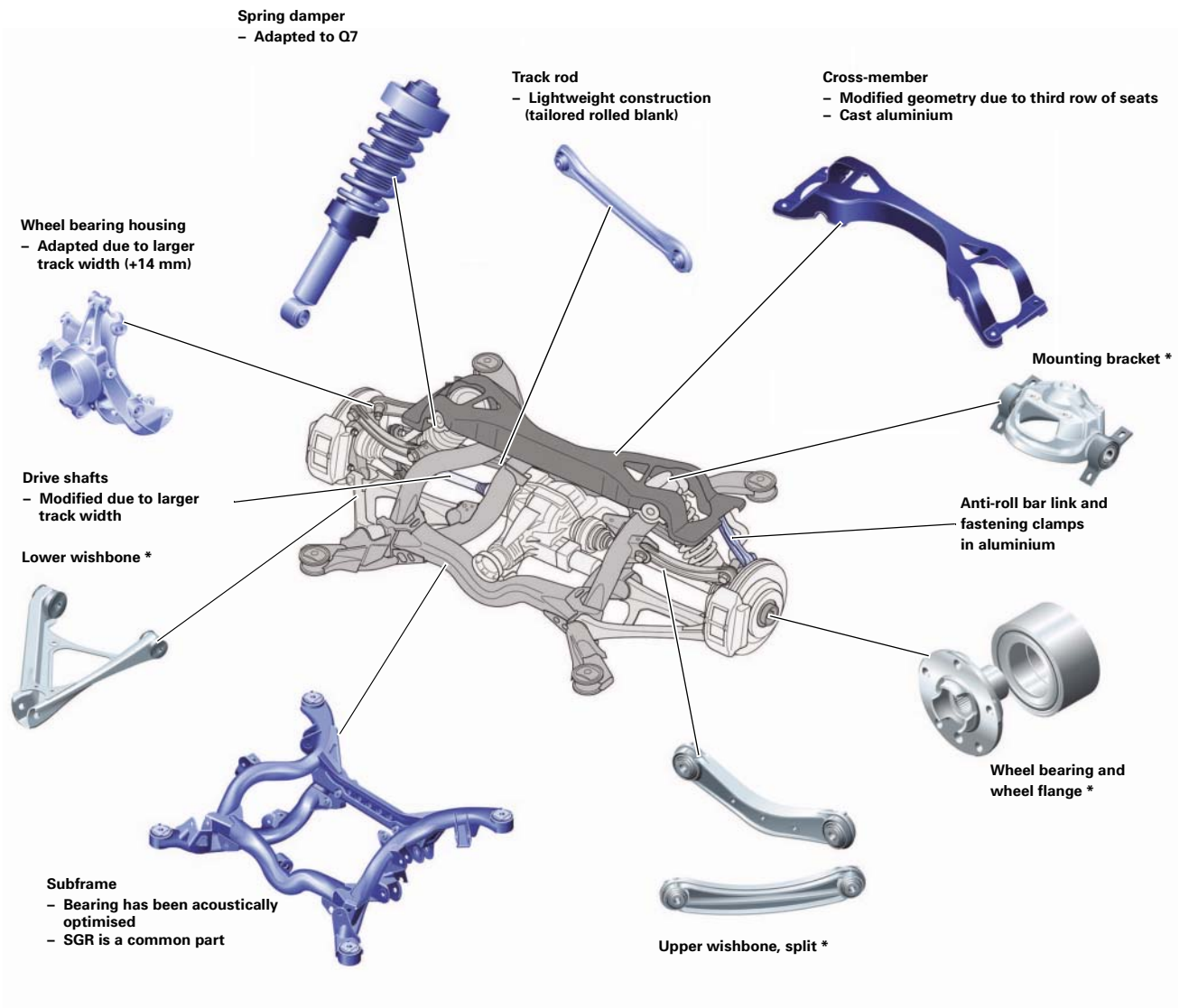

362_071

All parts marked * are common parts used in the VW Touareg

Brake system

Overview

	Front axle	Rear suspension	
Engine	V8 petrol engine, V6 FSI + TDI	V8 petrol engine	V6 FSI + TDI
Minimum wheel size	18"	18"	18"
Brake type	Brembo aluminium fixed caliper	Brembo aluminium fixed caliper	Brembo aluminium fixed caliper
Number of brake pistons	6	4	4
Brake piston diameter (mm)	30/34/38	28/32	28/30
Brake disc diameter (mm)	350	358	330

Front wheel brakes

Ventilated brake discs are employed. Brake lining wear is monitored. The aluminium brake calipers use a monoblock construction.



Rear brakes

Ventilated brake discs are used. Brake lining wear is also monitored at the rear axle. A servo drum brake is employed as the handbrake.



Brake system

Foot-operated handbrake

Overview

A foot-operated handbrake is used for the first time in an Audi vehicle. The technical concept was adopted from the VW Touareg. Geometric modifications were made in the area of the release handle in the dash panel and the release cable.

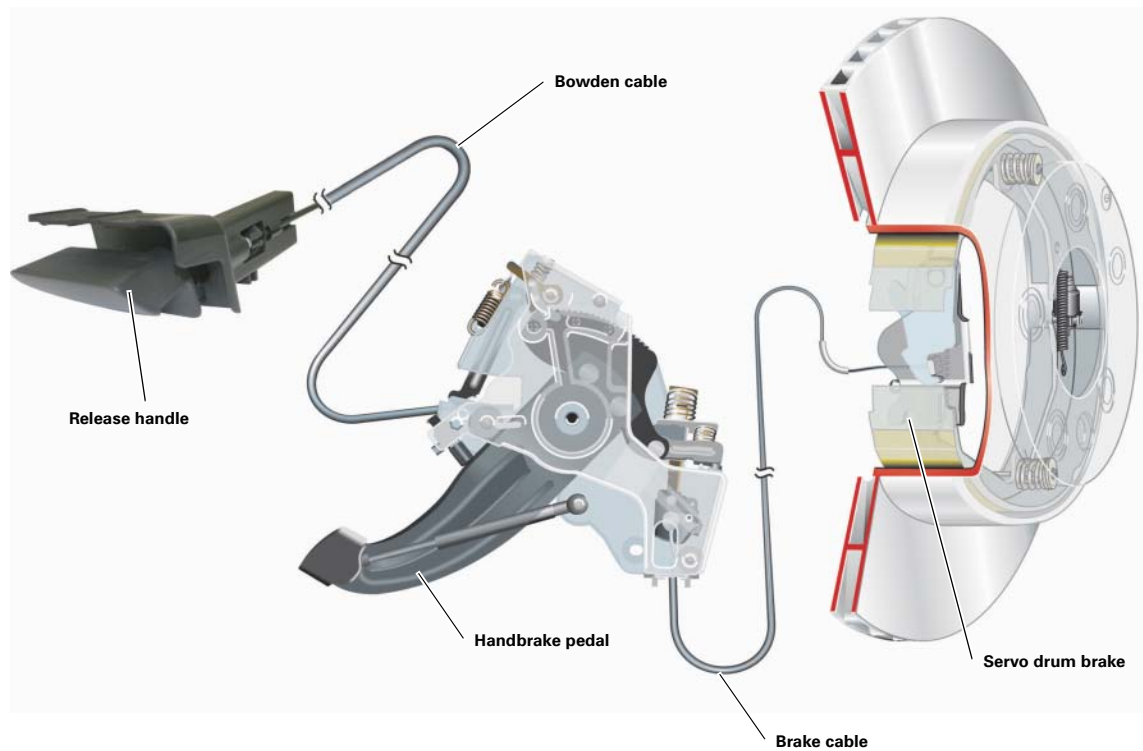

362_038

Foot-operated handbrake

Operating the brake

The brake cable is actuated by pressing the pedal. In the pressed position, the pedal is located in place by a locking pawl, which engages in the tooth segment attached to the pedal.

The locking pawl is mounted rotatably in the pedal mount. A spring presses the locking pawl against the tooth segment. The brake cable remains actuated, and the vehicle is braked.

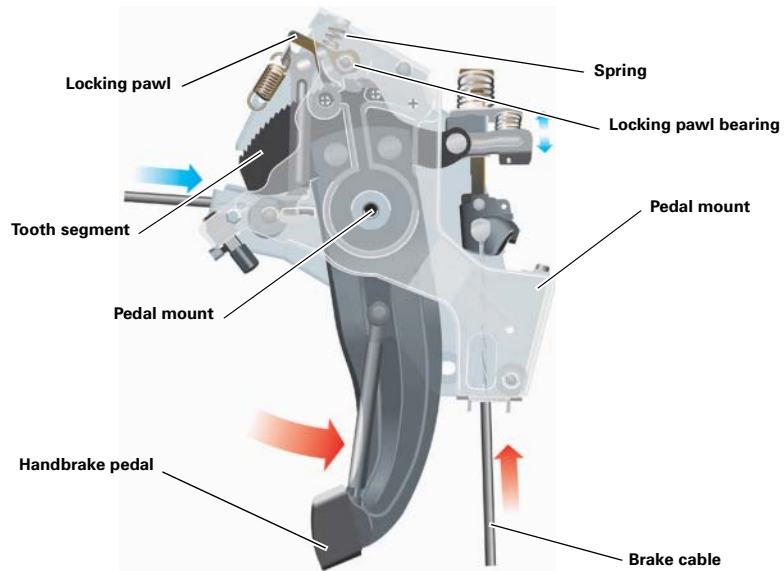

362_039

Releasing the applied brake

When the release handle is operated, the locking pawl is lifted by the release lever against the spring force. The locking pawl is lifted out of the tooth segment, and the pedal is unlocked.

The pedal slowly returns to its starting position against the damping force of the damper element. The brake cable is moved in the opposite direction and releases the handbrake.

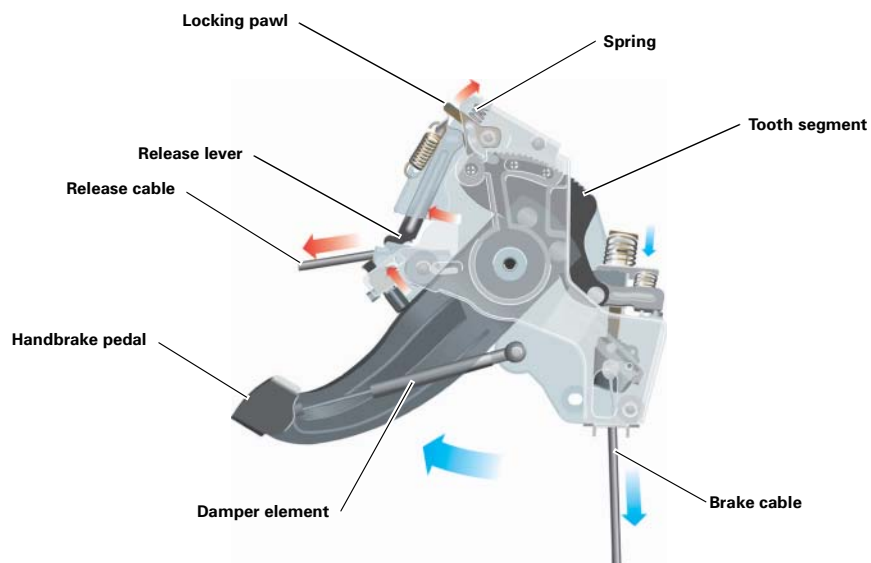

362_040

Brake system

Foot-operated handbrake

Automatic adjustment

Stretching of the bowden cable and settling of the bearings results in a progressive increase in backlash in the actuator mechanism. The handbrake requires adjustment to ensure proper functioning. These adjustments are made automatically in the Q7. The adjustment mechanism is attached to the handbrake pedal. The adjustment mechanism is located between the pedal and the bowden cable.

Configuration with actuated handbrake:

The connection between the handbrake pedal and the bowden cable is made by means of a rack. The rack is rigidly attached to the cable pull on one side. The rack is located in a control arm. This rack control arm is attached rotatably to the tooth segment. The release spring presses the control arm against the rack and locates it in position on the handbrake pedal. This makes a rigid connection between the pedal and the brake cable.

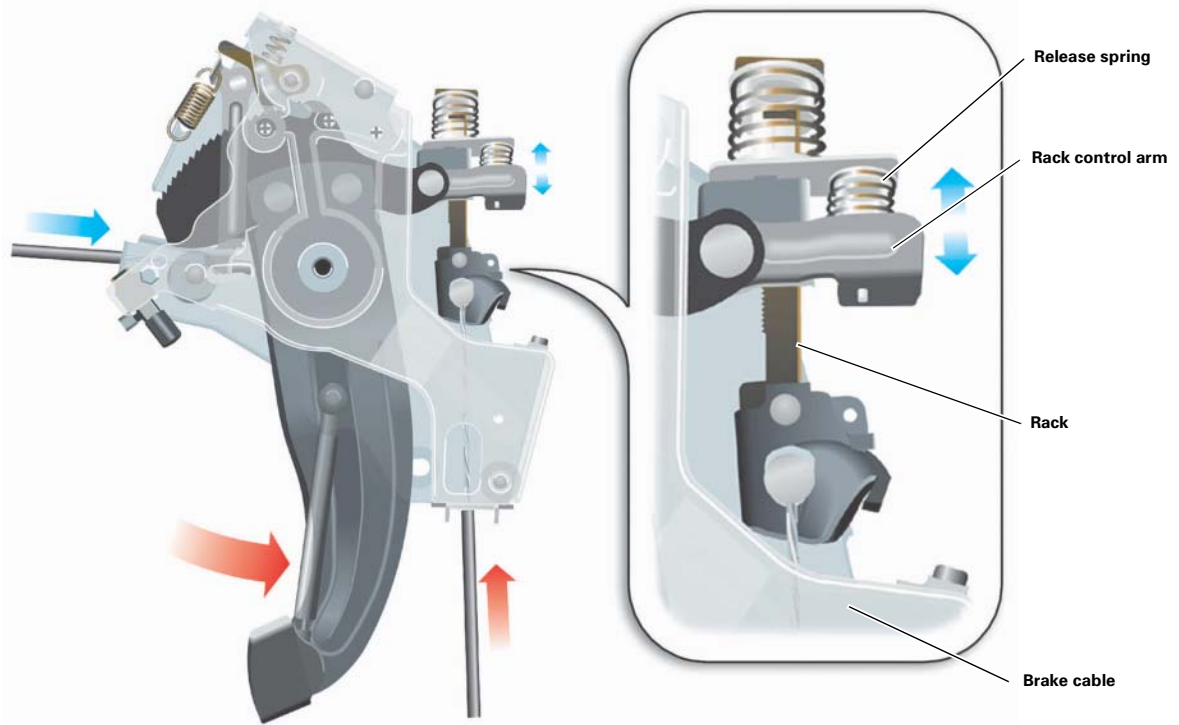

362_041

Foot-operated handbrake

Mode of operation of the adjustment mechanism:

When the release lever is operated, the handbrake pedal returns to its starting position. At the same time, the rack control arm comes into abutment with the stop. The rack control arm is then pushed upwards against the spring force of the release spring, releasing the rack.

The adjuster spring pulls the rack upwards until the backlash is compensated. When the handbrake pedal is operated anew, the rack control arm is again pressed against the rack by the release spring and locates the rack in position.

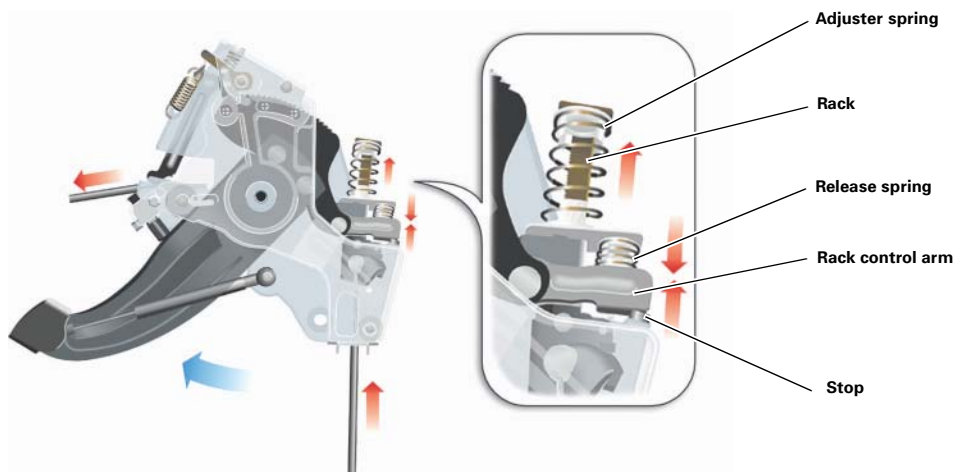

362_042

Servo drum brake

When the brake cable is pulled, both brake jaws are pressed simultaneously against the brake drum by the spreader lock.

As before, basic adjustment of the handbrake is made using an adjustment screw.

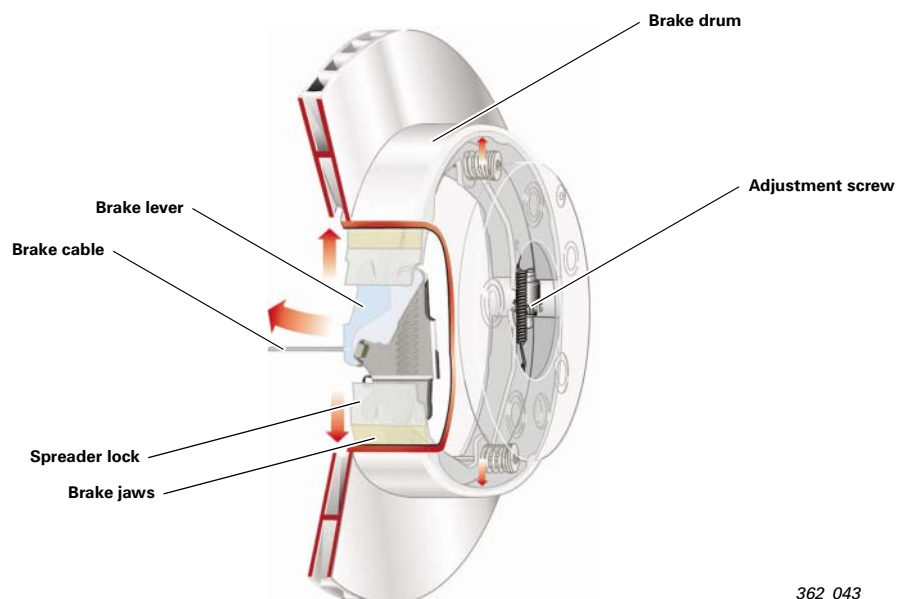

362_043

Brake system

The active brake servo

The task of the active brake servo is to build up brake pressure without operation of the brake pedal by the driver. This is a requirement for specific ESP control operations. Rapid pressure build-up is essential particularly for roll-over stabilisation and for ESP intervention if the vehicle is oversteering.

For this purpose, pressure is built up by activating the active brake servo on the suction side of the ESP pump. The delivery rate of the ESP pump increases, allowing a more rapid pressure build-up.

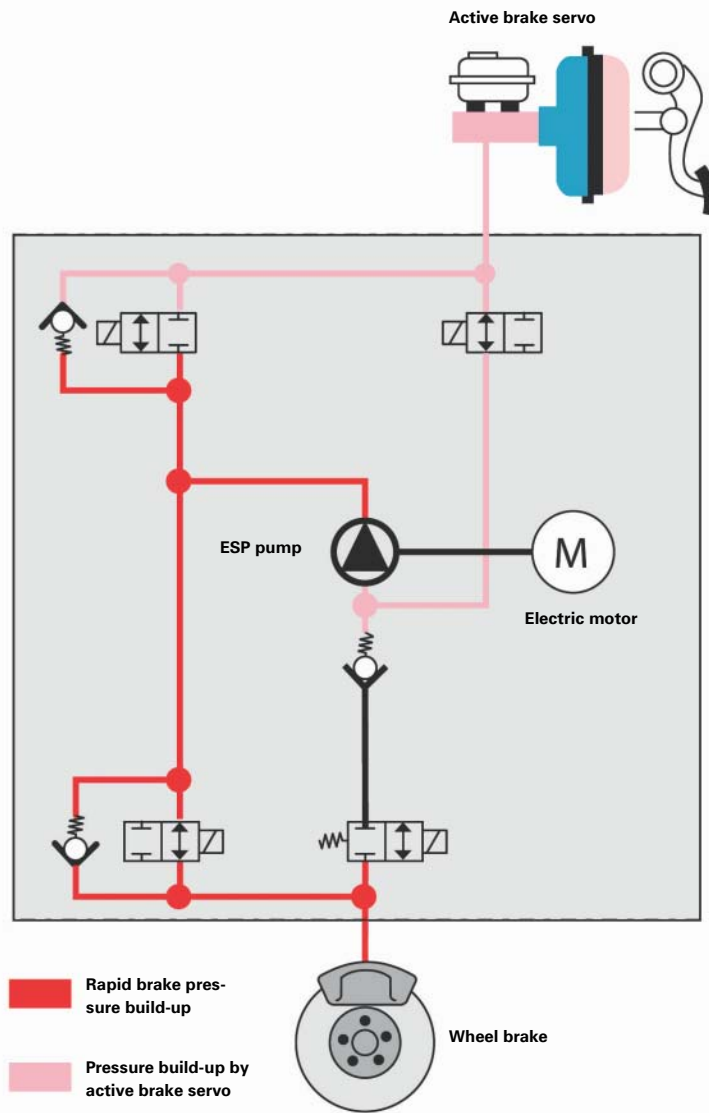

362_070

The active brake servo

Design

Compared to a conventional, passive brake servo, an electro-magnetically operated valve is integrated in the active brake servo. A proportional solenoid (continuously variable adjustment proportional to excitation current) is used to actuate the valve.

The solenoid is activated by the ESP control unit. A release switch in the active brake servo recognises whether the driver has applied or released the brake. The release switch is designed as a two-way switch (NC contact and NO contact).

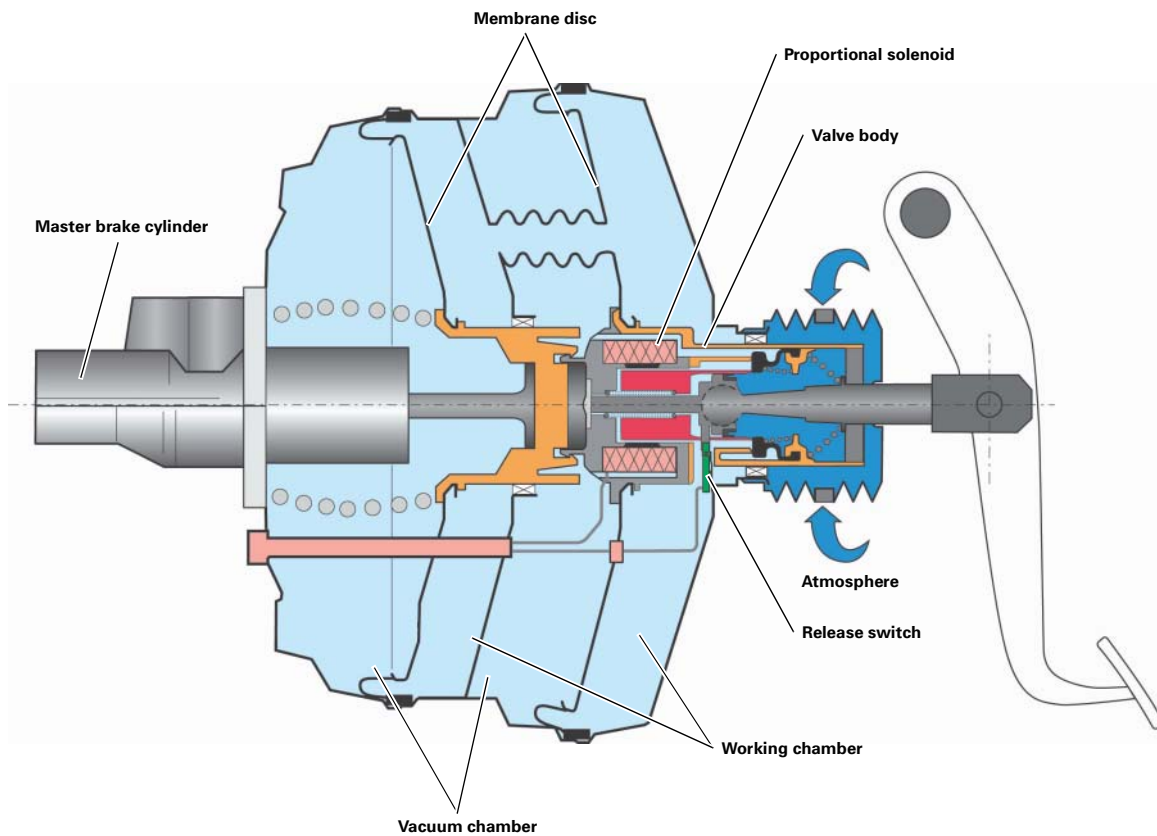

362_045

Brake system

The active brake servo

Function of the release switch

In the rest position or when the electronic brake servo is actuated electrically, the release switch contacts the housing of the active brake servo and closes electrical circuit 1.

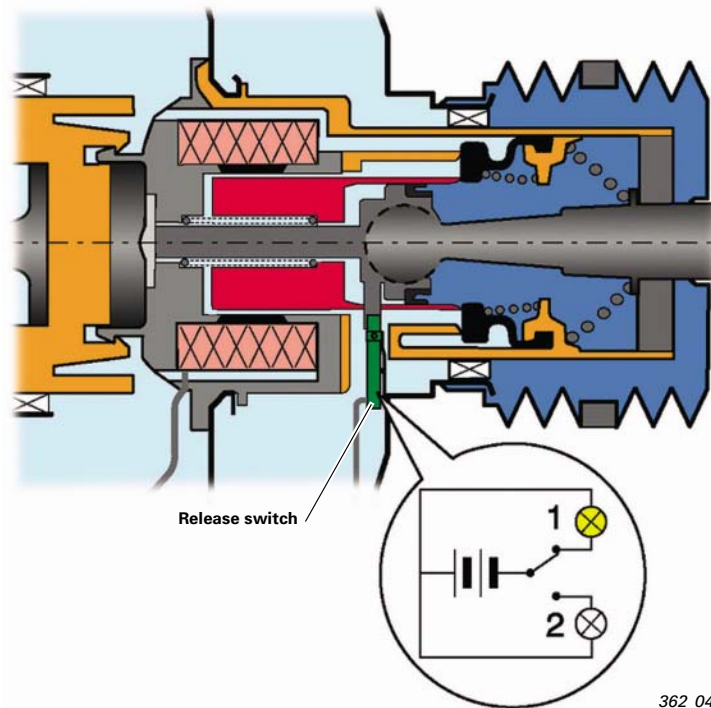

If the driver applies the brake pedal, the actuating rod is moved. This release switch moves away from the active brake servo's housing. Electrical circuit 1 is opened, electrical circuit 2 is closed.

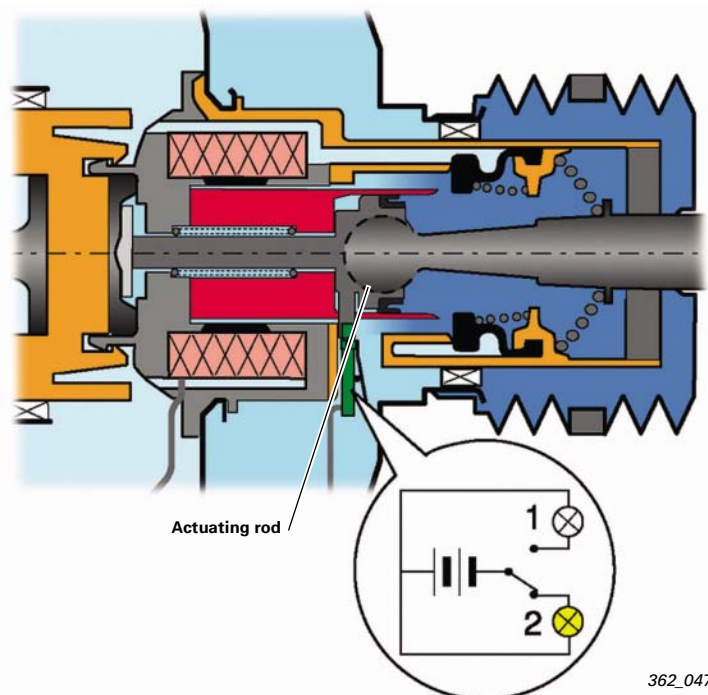

The active brake servo

Function of the active brake servo

Non-actuated state

The proportional solenoid is not energised, the brake pedal is not applied. The function of the active brake servo is determined by the sealing edges - which act as a valve - and by the disc seal. Depending on the position of the valve edges, a defined pressure builds up inside the working chamber of the active brake servo.

When the active brake servo is in a non-actuated state, as described, both valves are closed by application of the sealing edges to the disc seal. In the working chamber, the vacuum provided by the vacuum supply (suction tube or pump) is applied.

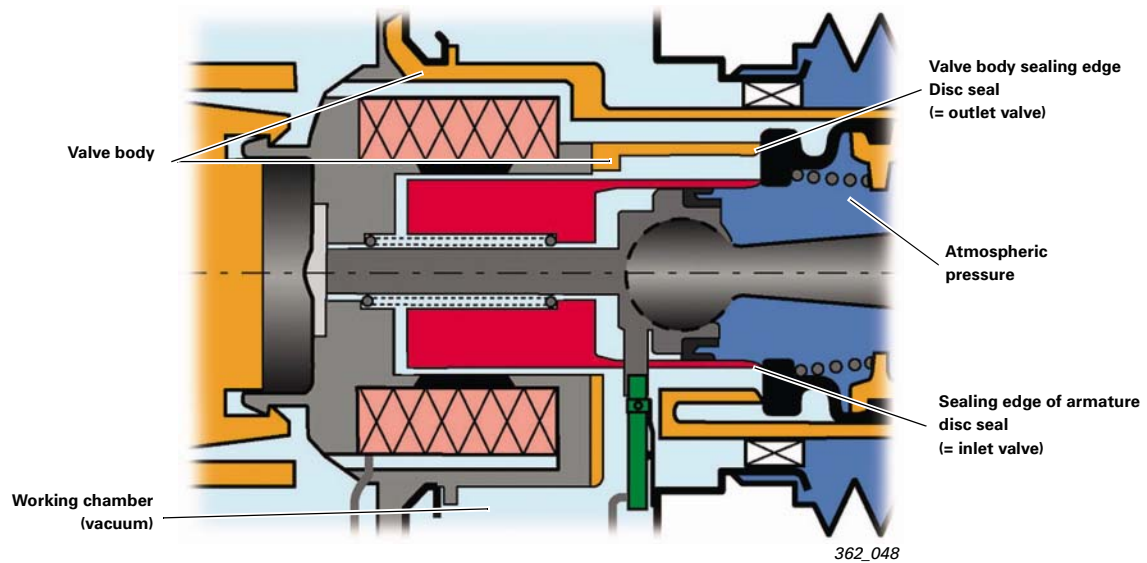

Pressure build-up

The proportional solenoid is energised by the ESP control unit. The armature is brought into abutment with the stator by the magnetic force acting against the armature spring in the direction of the arrow. The sealing edge of the armature lifts off the disc seal, and the inlet valve opens.

Air under atmospheric pressure flows into the working chamber.

Due to the pressure difference between the vacuum chamber and the working chamber, the membrane discs are moved in the direction of the master brake cylinder (in direction of arrow), and thus brake pressure is built up.

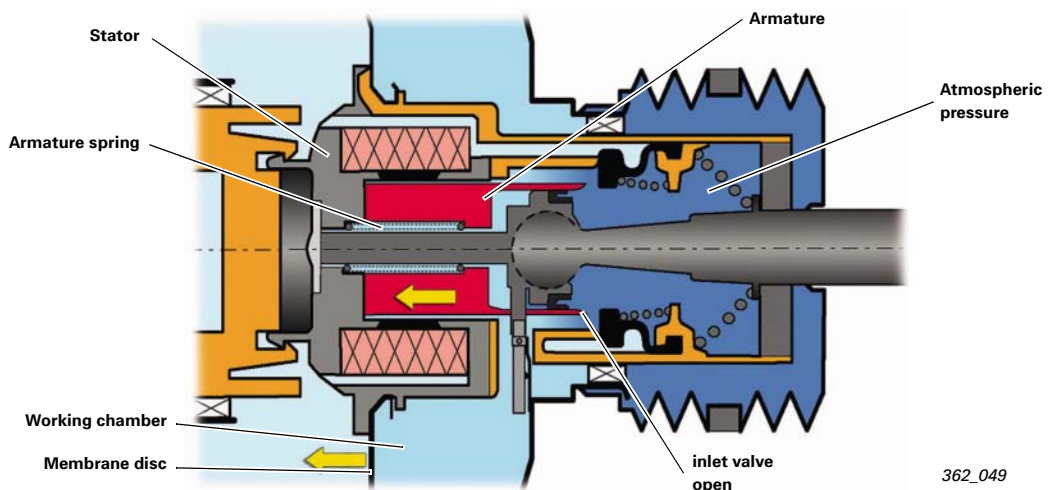

Brake system

The active brake servo

Function of the active brake servo

Pressure retention

The electrical current in the magnetic coil is reduced. As a result, the armature spring pushes the armature away from the stator (direction of arrow).

The sealing edge of the armature against comes into abutment with the diaphragm spring, and the inlet valve is closed. The partial vacuum in the working chambers remains constant, as does the brake pressure.

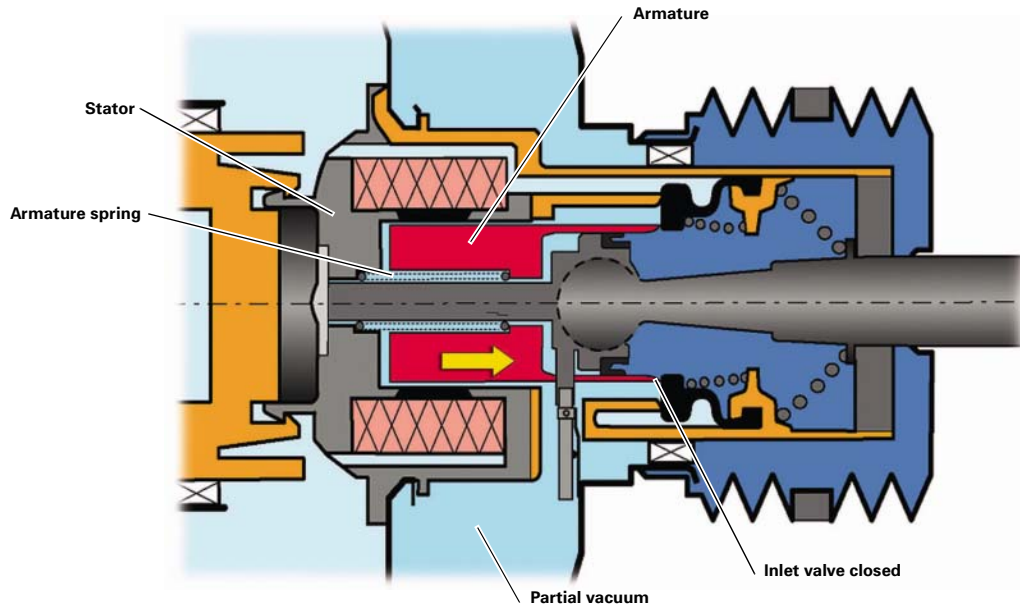

Pressure reduction

If the magnetic coil is deenergised, the armature spring pushes the armature and the stator further apart. The armature pushes the diaphragm spring back over the sealing edge of the inlet valve. The outlet valve is opened.

A connection is made between the working chambers and the vacuum chambers. The air flows from the working chambers into the vacuum chambers until pressure between the chambers is equalised.

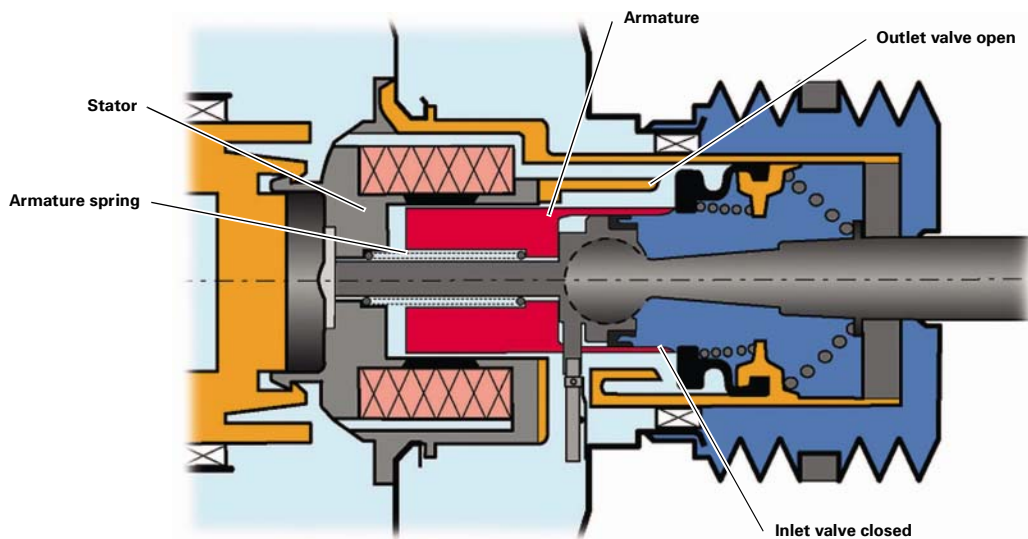

Overview

A new ESP unit by Continental-Teves with the designation Mk25E1 is used in the Audi Q7.

The differences between the Mk25E1 and the current Mk60IS ESP unit employed in the current Audi A3 are as follows:

- Extended functions
- Upgraded hydraulic pump
- More powerful electric motor
- Larger internal reservoirs
- Active engine speed sensors with forward/reverse travel detection and installation position recognition

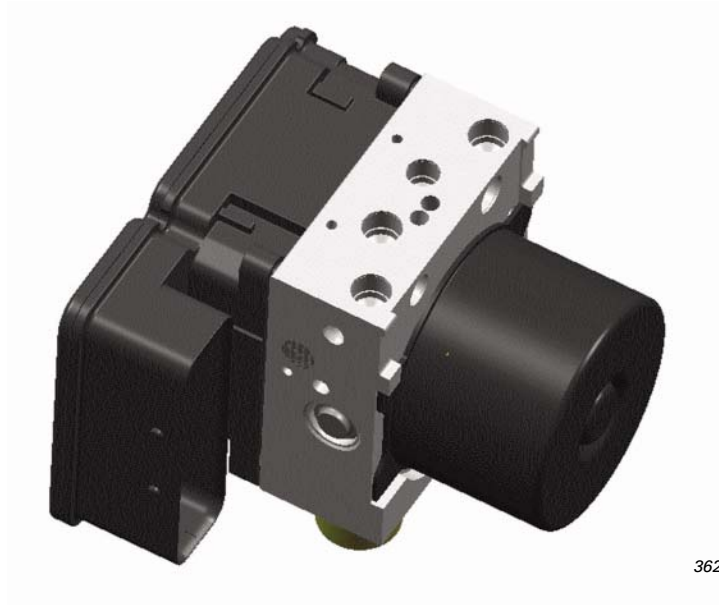

362_052

Definition of the designation Mk25E1:

- Mk25 = name of model series
- E = use of linearised switch valves* as changeover valves (2x) and inlet valves (4x)
- 1 = use of an integrated pressure sensor

Reference

Mode of operation: refer to SSP 285



Function overview

Known functions integrated in existing Teves ESP systems

- ABS (anti-lock braking system)
- EBD (electronic brake pressure distributor)
- TCS (traction control system)
- EDL (electronic differential lock)
- EBC (engine braking moment control)
- HBA (hydraulic brake assist)

New functions

- braking guard (only in vehicles with adaptive cruise control)
- Trailer stabilisation system
- Roll-over stabilisation
- Fading Brake Support (FBS)
- Brake disc wiper
- Emergency brake signal
- Offroad mode

New functions

braking guard

This function alerts the driver to an impending collision with a vehicle ahead. To utilise this function, the vehicle must be equipped with acc. The acc radar sensors gauge the distance to a vehicle ahead and its speed. The acc control unit processes these measured values and recognises collision hazards. The warning is issued in two stages:

1. The first warning is given by simultaneous activation of an audio-visual signal.

2. The brake pressure is built up for a short period of time. The acc control unit sends a CAN message together with the brake request to the ESP control unit. The ESP control unit activates the recirculating pump and briefly brakes the front axle.

Even if acc is not activated, braking guard is active.

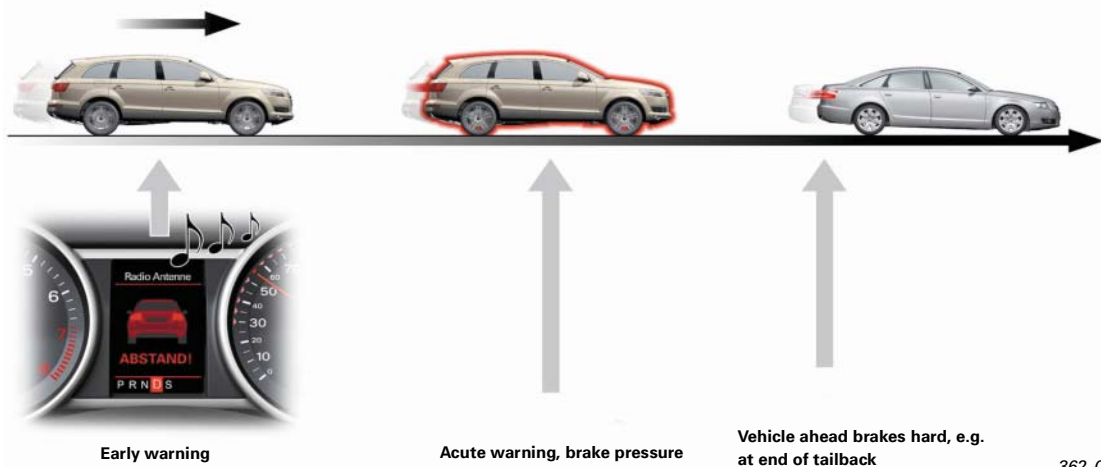

Trailer stabilisation system

This function is used in vehicles fitted with a tow bar. Slight back-and-forth swaying motion of a trailer can, in certain driving conditions, amplify to such an extent that a critical driving situation can develop. This situation usually occurs at road speeds between 75 and 120 kph. If the trailer begins to swing back and forth above this critical speed threshold, the oscillation amplitude of the trailer will increase progressively. The back-and-forth swaying motion also excites periodic oscillation of the towing vehicle about its vertical axis.

These yaw movements are monitored by the yaw rate sender and evaluated by the ESP control unit. Initially, the ESP control system alternately makes brief corrective adjustments at the front axle as required. If this is insufficient, the ESP control unit instructs the engine control unit to reduce torque in order to slow the vehicle down. All four wheels are braked simultaneously by the ESP. A coupled and electrically connected trailer is detected automatically by the ESP control unit.

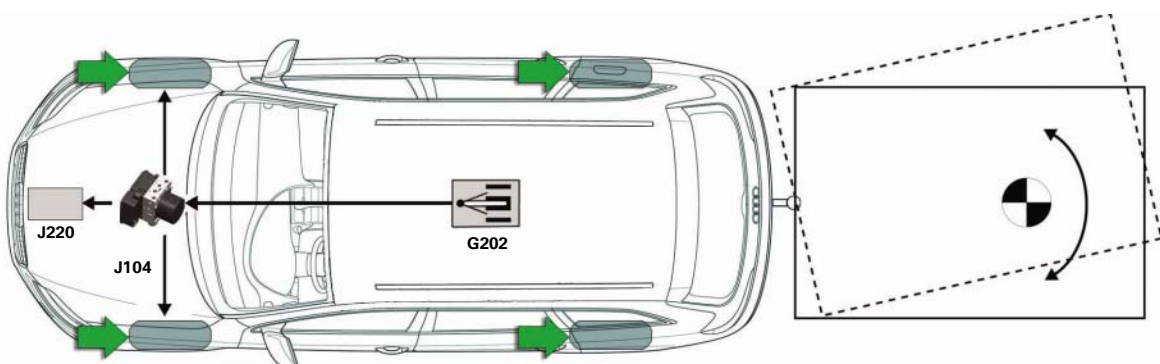

New functions

Roll-over stabilisation

If the vehicle is in danger of rolling over, it is stabilised by reducing the lateral acceleration. This is achieved by massive corrective braking at the front axle. In addition, engine torque is reduced. The driver may notice some intervention, but will not yet have registered the critical driving situation (as of approx. 0.6g lateral acceleration). The ESP warning lamp flashes while ESP is active.

Brake pressure is built up by activating the active brake servo and through active pressure build-up by the ESP. The active brake servo provides rapid pressure build-up on the intake side of the ESP recirculating pump. This enables the ESP to build up brake pressure very quickly.

Emergency brake signal

The flashing warning lamps are activated during braking operations involving very high rates of deceleration or braking operations in the ABS operating range.

Fading Brake Support (FBS)

If braking performance decreases due to low coefficients of friction between the lining and the brake disc, the ESP pump builds up additional pressure to compensate for the loss of brake pressure.

This is the case when a high brake pressure is measured, but the conditions at the wheels are outside the intervention range of the ESP. The FBS function is deactivated as soon as the driver reduces the brake pressure considerably. This is not indicated.

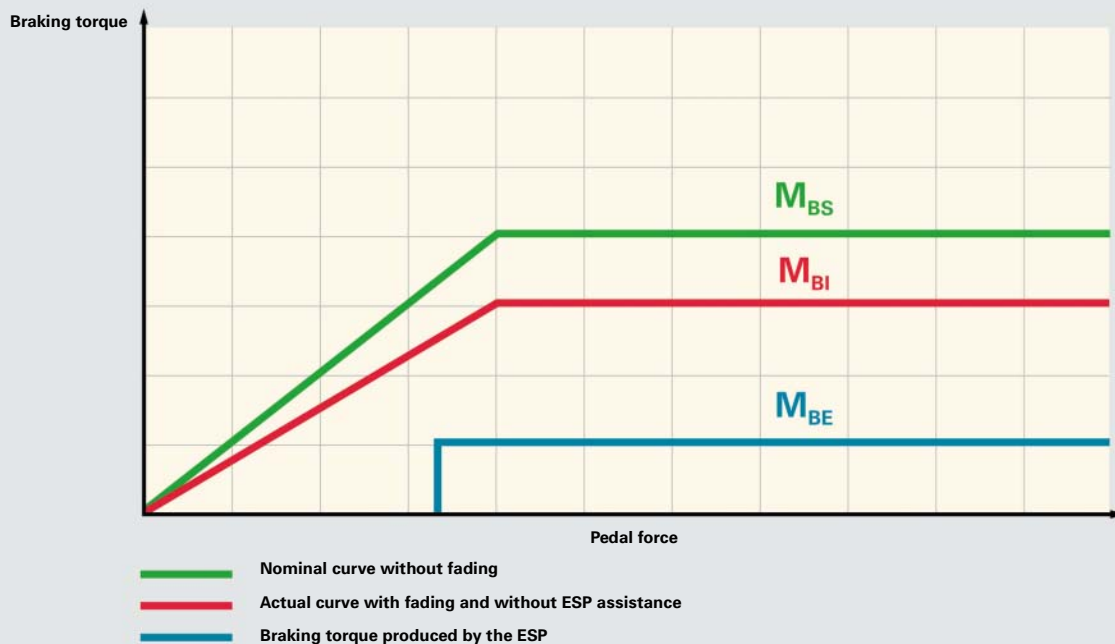

$$M_{BI} + M_{BE} = M_{BS}$$

New functions

Brake disc wiper

If a speed signal greater than 50 kph and a windscreen wiper command (incl. also when the wiper is in intermittent mode) are present on the CAN bus, the front brake pads are applied to the brake discs approx. every 3 km for a duration of approx. 8 seconds in order to remove any water film from the brake discs.

For this purpose, the ESP starts up and applies a pressure of approx. 0.8-1.2 bar. The function is not indicated to the driver. The function interval is reset whenever the brake is applied.

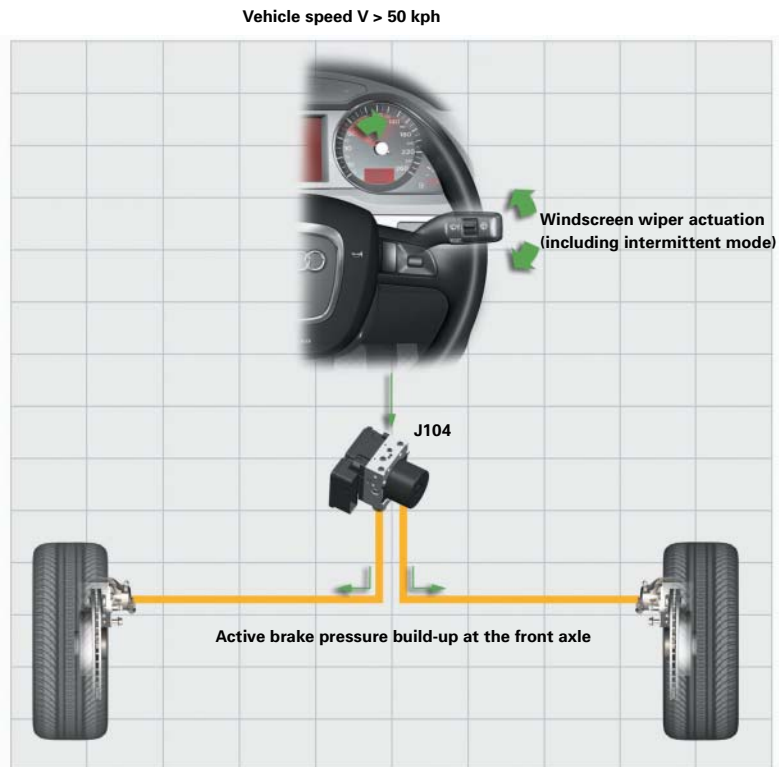

362_056

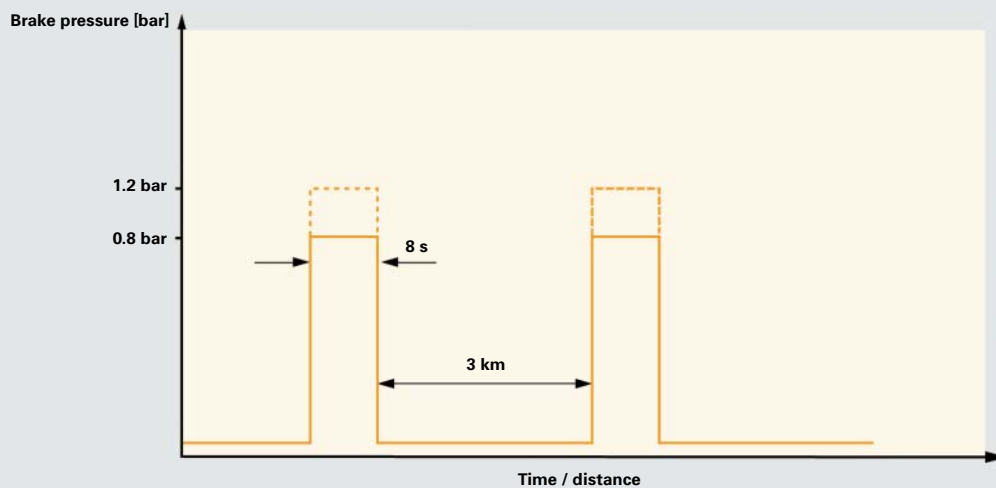

362_066

ESP

New functions

Offroad mode

The basic function of the Offroad mode is to optimise ESP/TCS/EDL and ABS intervention with regard to traction and braking performance on loose surfaces (offroad). The thresholds for ESP/TCS and ABS intervention are variable depending on the vehicle's road speed.

Larger wheel slip values are allowed until one of the control systems is activated.

The EDL function is activated even at low speed differentials.



362_058

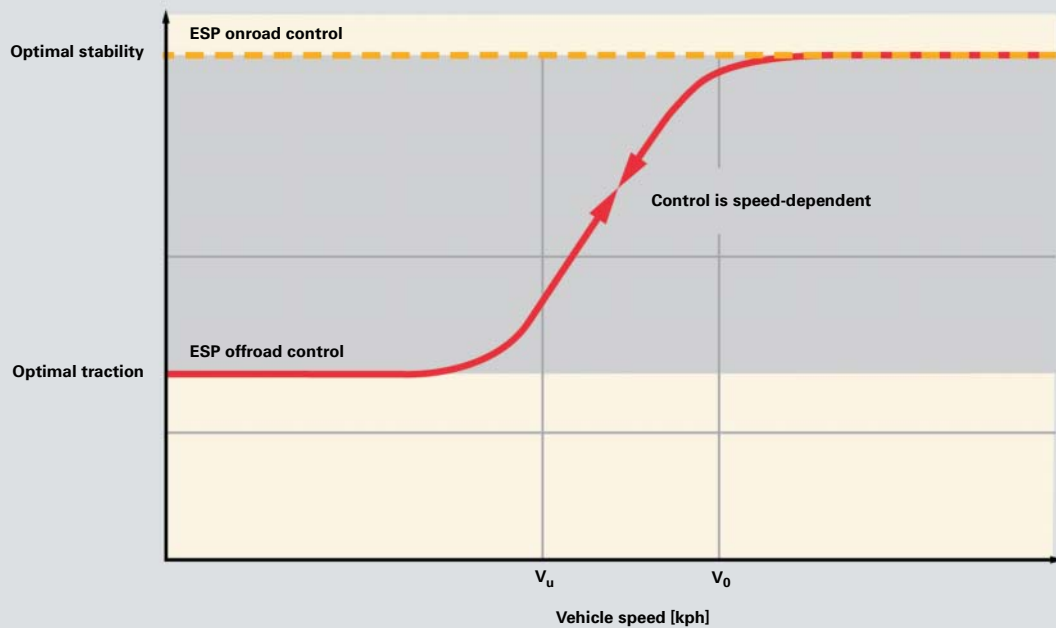

362_057

Activation:

The mode is activated by pressing the ESP button briefly (<3s).



362_059

Display:

The message "offroad" appears on the display of the driver information system; yellow ESP warning lamp is activated



362_060

New functions

Offroad mode

- The trailer stabilisation system is deactivated, because oscillation of the trailer would otherwise be erroneously detected incorrectly due to the offroad surface conditions.



362_061

- Activation of "ABS while reversing"

If the vehicle is rolling backwards down a slope, the rear axle is braked less than the front axle by the EBD function. While the vehicle is reversing, the rear axle is now treated like a front axle from a braking viewpoint, and a greater brake pressure is applied to the rear axle.

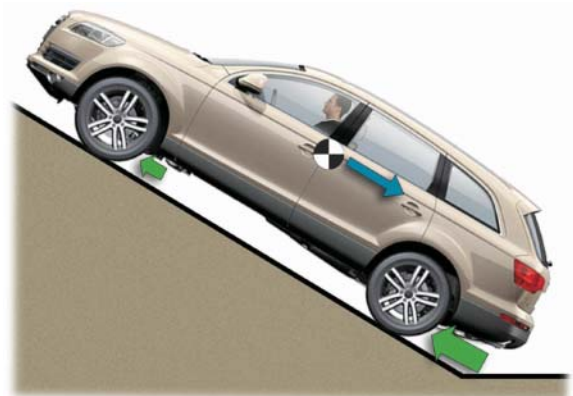

362_062

- Activation of the "hill descent assist" system;

The hill descent assist system assists the driver through brake activation in steep falling terrain with gradients of approx. 10-15% and at speeds up to 20 kph. The function is activated if different wheel speeds occur while driving downhill due to slippery surfaces or wheels lifting off the ground due to axle articulation on very uneven terrain. The objective is to enable the vehicle to negotiate the incline at a constant speed without any intervention by the driver.

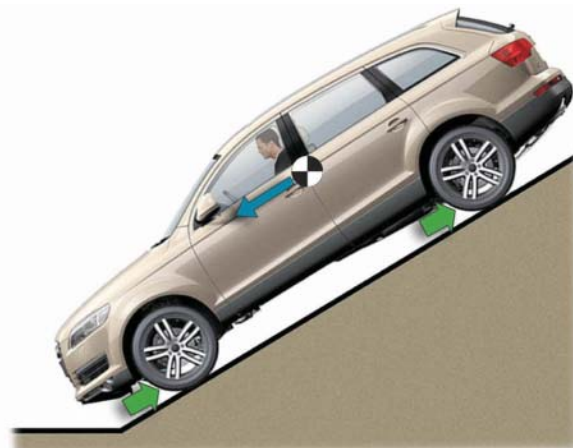

362_063

Note



It is not possible to deactivate the ESP system in Offroad mode by pressing the ESP button.

System components

Hydraulic unit and control unit

Compared to the Mk60, an updated hydraulic pump is employed for the hydraulic unit. Thus, in combination with a more powerful electric motor, larger amounts of brake fluid can be conveyed in the same time. This is a necessary feature because the brake calipers in the Q7 have a much higher volumetric capacity than the brake calipers in previous Audi models.

Accordingly, the internal reservoirs have also been enlarged compared to the Mk60. The control unit is bolted to the hydraulic unit in the usual manner. The terminal pin assignments are identical to those of the Mk60 series.

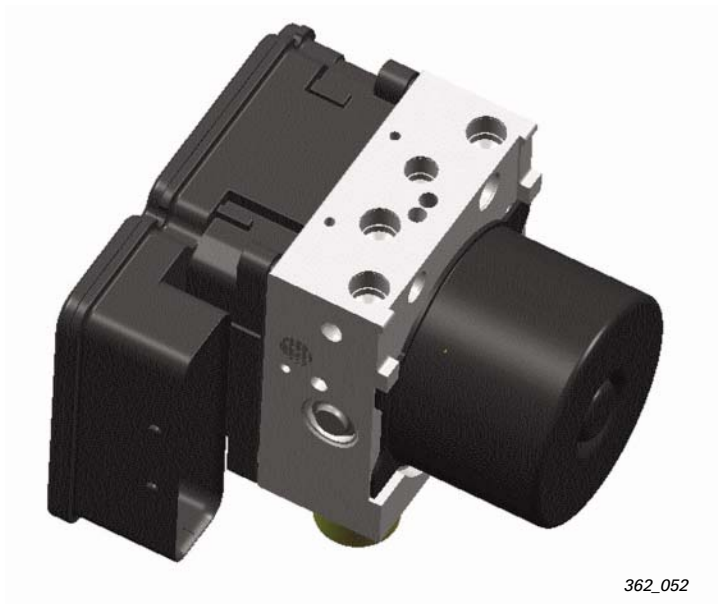

362_052

Speed sensors

Active speed sensors are used in the Q7.

The advantage of these sensors is that they can detect forward/reverse travel, as well as the installation position.

The sensors utilise the Hall effect.



362_080

Reference



For detailed information on the design and mode of operation, please refer to SSP 285

System components

Brake light suppression relay

Activation of the solenoid of the active brake servo produces slight movements of the brake pedal without action by the driver. Thus, the brake light switch is actuated. The switching of the brake light switch is read in by the engine control unit. The engine control unit then instructs the convenience system central control unit J393 to activate the brake lights. Control unit J393 receives the signal simultaneously from the brake light switch along a discrete line.

Control unit J393 activates the brake lights if the CAN message and/or the discrete signal is/are present. However, the brake servo is also activated during corrective braking operations in which the brake light is not to be activated. In these cases, the relay suppresses transmission of the discrete signal. For this purpose, the ESP control unit switches the relay and signals the engine control unit that it should not activate the brake lights.

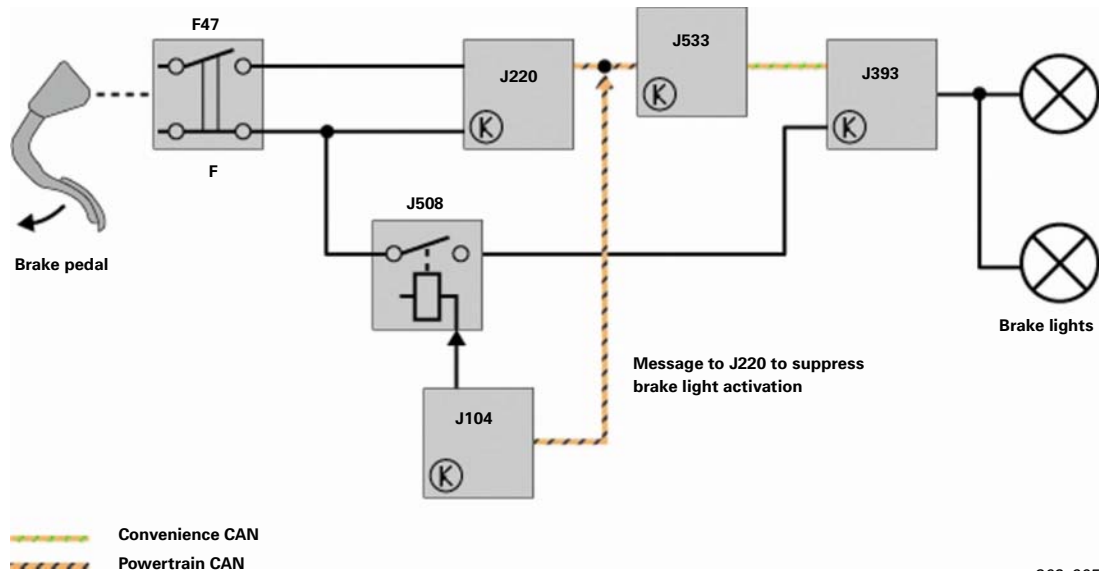

362_065

- J220 Motronic control unit
- J104 ESP control unit
- J53 Data bus diagnostic interface
- J393 Convenience system central control unit
- J508 Brake light suppression relay
- F47 Brake pedal switch
- F Brake light switch

Note



The brake light suppression relay is not included in the system diagnostics.

Service work

New service procedures:

Encoding of the control unit

The following information is encoded:

- Brake equipment
- Suspension variant (aas or conventional suspension)
- Engine variant
- Towing attachment (not in USA)

Final control diagnostics

As the last step in the final control diagnostics, all valves required for EDL operation and the ESP pump are activated. All wheels on the vehicle must be braked if the valves are functioning properly.

Data blocks

The following measured values have been implemented in addition to the values known from the Audi A6:

- Status of brake pressure solenoid trip switch F84 (in place of brake light switch signal)
- Trailer detector
- Status of handbrake (foot-operated handbrake)

In the Q7 too, the coding of the ESP control unit is checked by comparing the encoding information to the information stored in the airbag control unit. The information on drivetrain type and brake equipment is compared during each initialisation (terminal 15 ON).

Overview

Steering system

A conventional hydraulic steering system with rotary vane pump, rotary slide valve and rack-and-pinion steering gear is used. Depending on engine variant, steering pumps with various delivery rates are used (11 cm³/revolution for V6 engines, 14 cm³/revolution for V8 engines).

The servotronic function is standard.

The Servotronic II from the current Audi A8 is employed (see SSP 285).

The servotronic solenoid valve is activated by onboard power supply control unit -2- J520.

Steering wheels

The design and function of the steering wheels have been adopted from the current Audi A6. The geometric shape of the airbag gas ducts was adapted.

The programme includes three-spoke and four-spoke steering wheels. These steering wheels are optionally available with a leather cover, multi-function buttons, Tiptronic and heated steering wheel rim.



362_069



362_064

Steering column

A mechanically adjustable steering column is offered as standard equipment. The steering column has the same multi-disc clamping system as the steering columns used in the Audi A8 and Audi A6 (see SSP 285). The steering columns of the Q7 are also equipped with an electrical steering lock.

The steering lock has the same design and mode of operation as the steering column used in the A6. In the Q7, the complete structural unit is also attached unseparably to the steering column for reasons of anti-theft protection.



362_034b







An electrical steering column is offered as optional equipment. The electrical drives have been adopted from the steering column used in the Audi A8.



362_034a

Steering / wheels and tyres

Wheels overview

	 1	 3	 5	 6	 1
	 2	 4			
Engine	Basic wheels	Optional 18" wheels	Optional 19" wheels	Optional 20" wheels	Winter wheels
6-cylinder	7.5J x 18 ET 53 (1) aluminium forged wheel painted 235/60 R 18	8J x 18 ET 56 (3) aluminium forged wheel polished 255/55 R 18	8.5J x 19 ET 62 (5) aluminium cast wheel painted 265/50 R 19	9J x 20 ET 60 (6) aluminium cast wheel polished bicolor 275/45 R 20	7.5J x 18 ET 53 (1) aluminium forged wheel painted 235/60 R 18
8-cylinder	8J x 18 ET 56 (2) alu- minium forged wheel painted 255/55 R 18 <i>(available as optional equipment for 6-cylinder)</i>	8.5J x 18 ET 58 (4) aluminium cast wheel painted 255/55 R 18			

362_035

Tyre pressure check system

A tyre pressure check system is available as optional equipment for the Q7. The tyre pressure check system has the same design and mode of operation as the system used in the Audi A6.

Reference



For detailed information on the design and mode of operation, please refer to SSP 326

adaptive air suspension (aas)

Overview

The aas system in the Q7 is based on the system in the VW Touareg. With the exception of the springs and dampers, the axle components are identical to those of the steel-sprung suspension. The production control number (PR number) for the aas is 1BK.

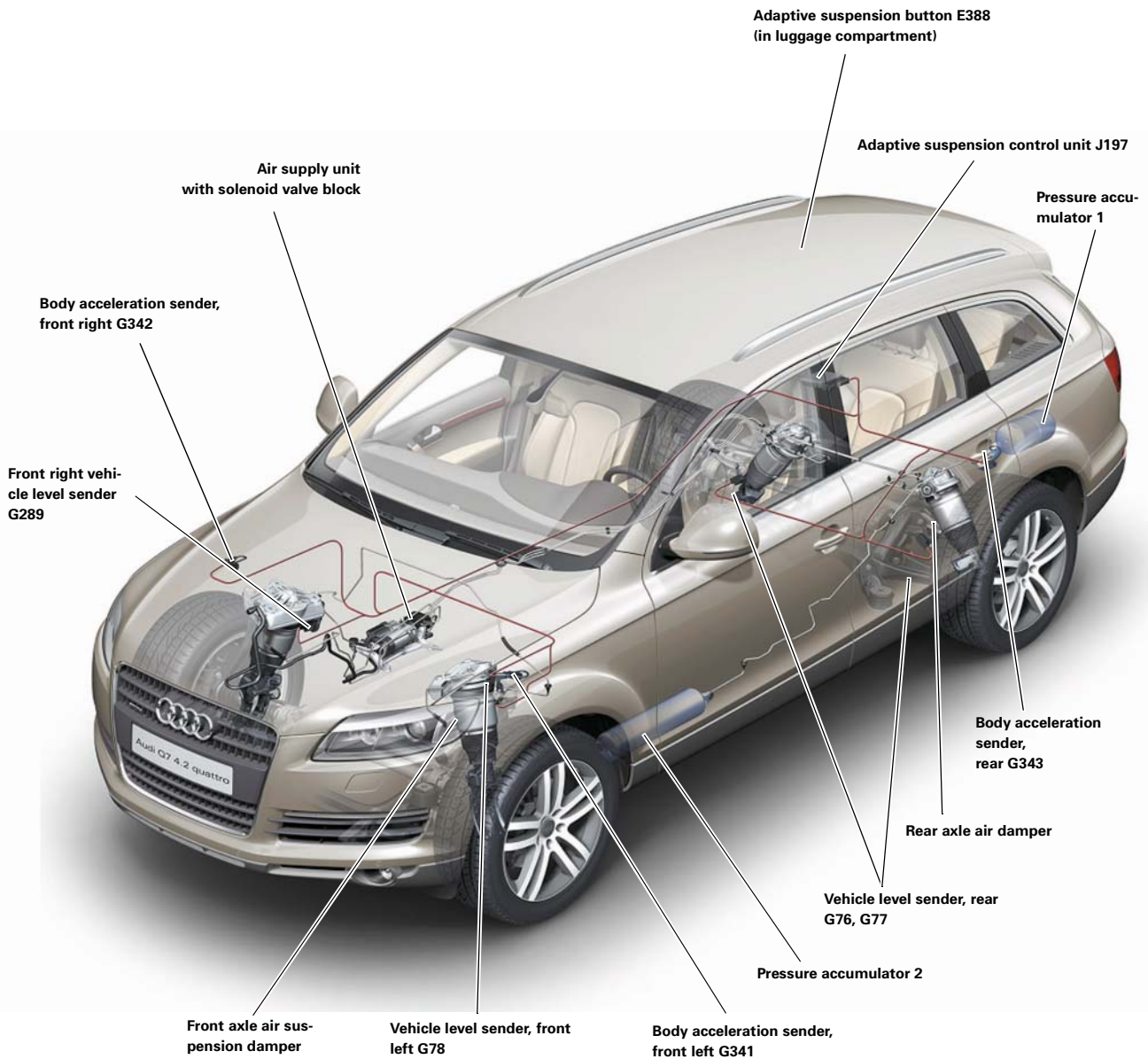

362_001

adaptive air suspension (aas)

Overview

System overview of networked components

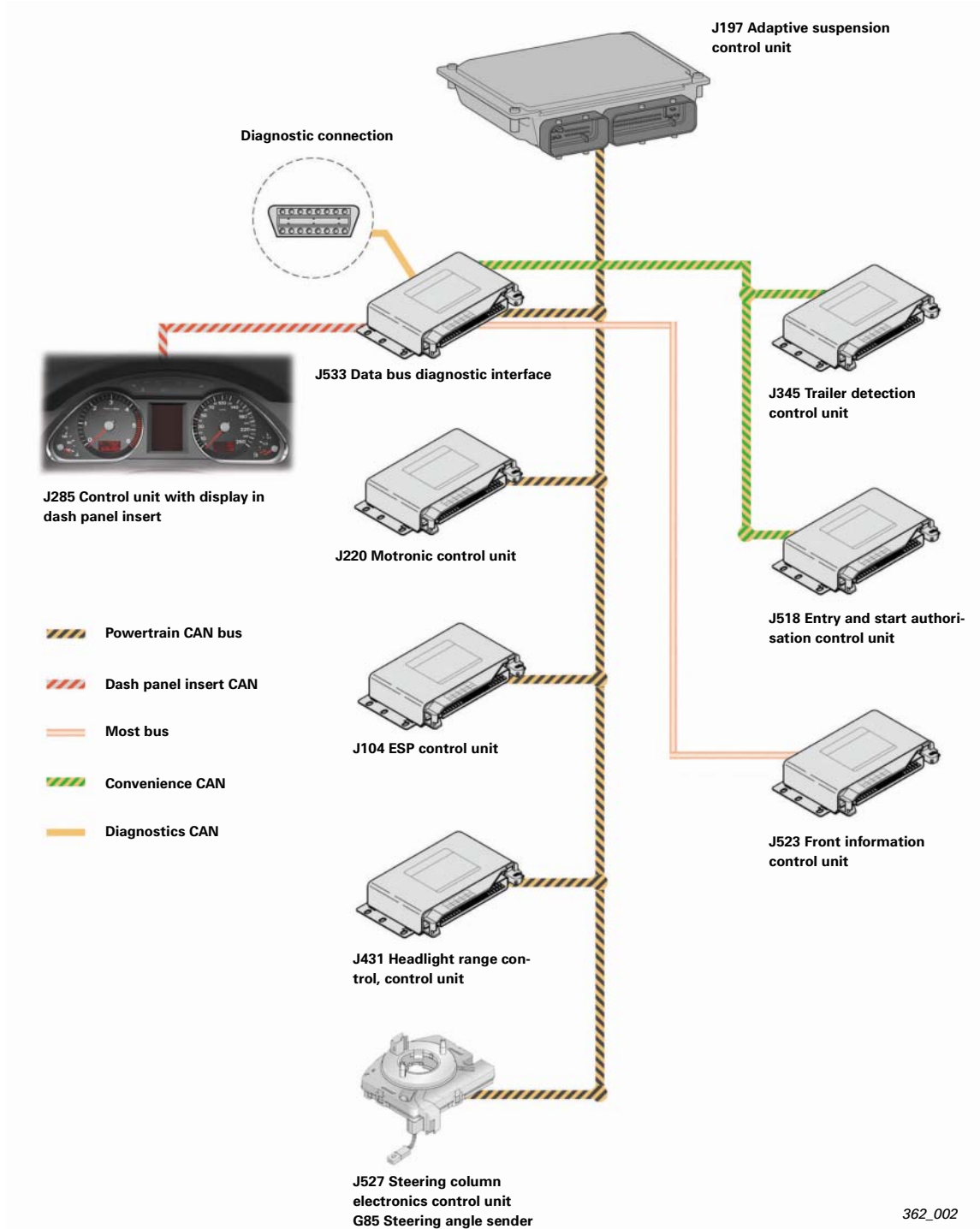

362_002

Overview

System overview of non-networked components

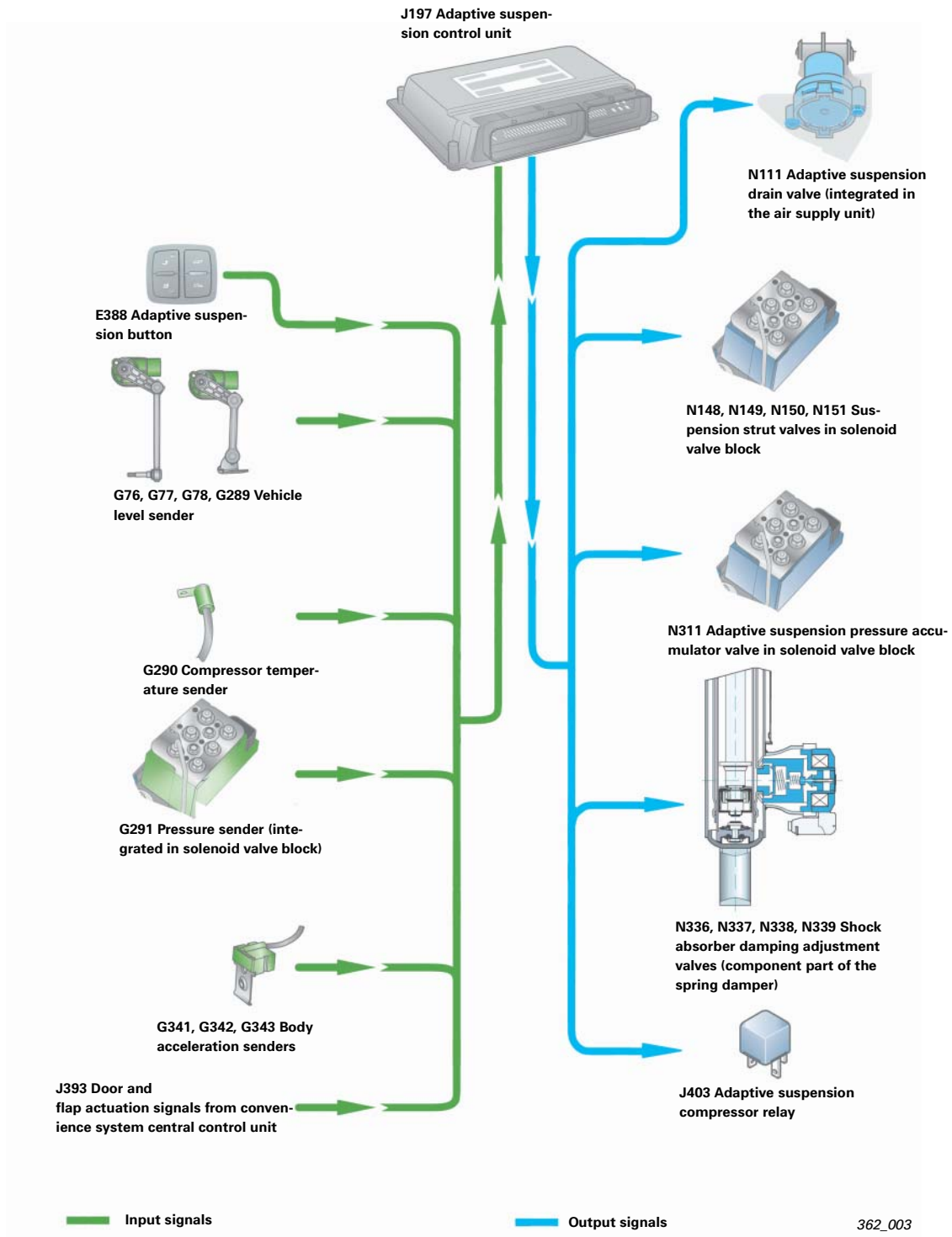

adaptive air suspension (aas)

Overview

Differences in design to the aas system in the Audi A6:

- Use of two pressure accumulators instead of one
- Larger air supply line cross-sections (Ø8mm instead of Ø6mm)
- All air lines are moulded parts, and not integrated the wiring harness
- Partially modified design of the system components (due to different manufacturer)

Differences in mode of operation to the aas system in the Audi A6:

- Additional mode: "offroad"
- Additional lowering of the rear axle by 45 mm below normal level for greater ease of loading
- Modified control strategy
- Modified operating and display elements

System components

Control unit J197

The control unit is located in the rack in the luggage compartment on the right. The control unit determines from the input signals the necessary signals for activating the damping valves, the compressor, the pneumatic switch valves and the driver information displays.

The adaptive suspension control unit has the same geometry and design as the control unit used in the Audi A8.

An additional input signal compared to A8 and A6 is the signal from the adaptive suspension button E388 in the luggage compartment for lowering the vehicle rear end in "load" mode.



362_004

System components

Air suspension damper

Air suspension dampers are used on the front and rear axles for the Q7. The spring/damper configuration is not separate like in the A6. The air suspension dampers are identical in design and function to the dampers in the VW Touareg. The roll piston geometry and the damper setup were modified for use in the Q7.

The residual pressure maintaining valves ensure that a minimum pressure of approximately 3.5 bar is maintained in the air springs even if a major leak occurs in the system.

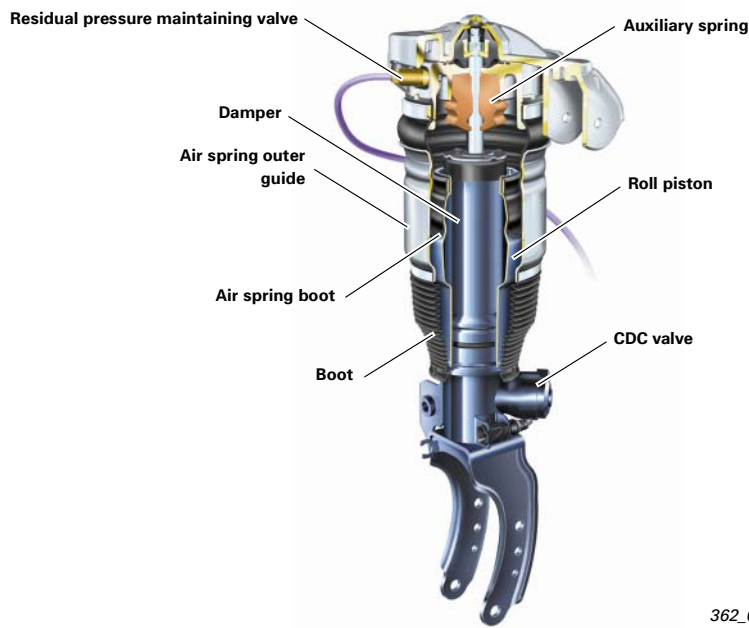

362_005

Rear axle air suspension damper

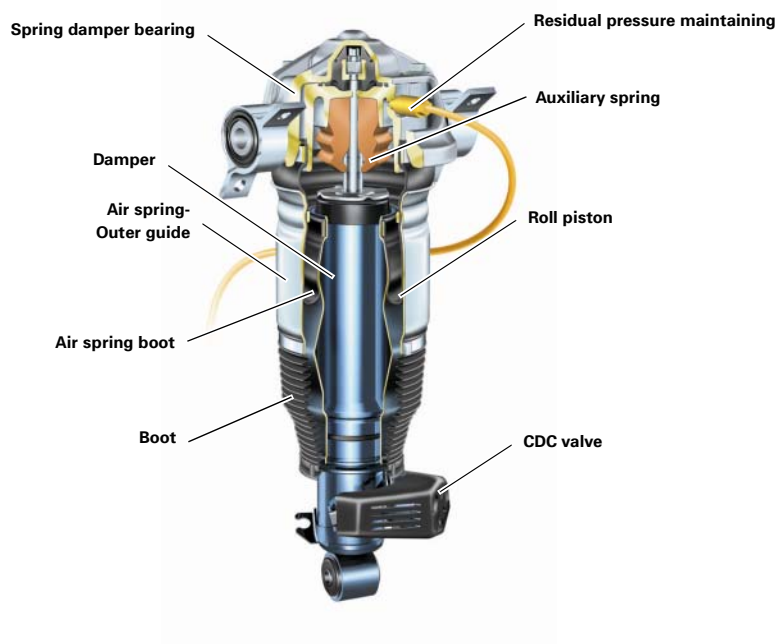

362_006

adaptive air suspension (aas)

System components

Air suspension damper CDC valve

A CDC valve (CDC = continuous damping control) is used for the damping control. The fundamental difference to the CDC valve used in the A8 is that the valve in the Q7 is attached to the exterior of the damper tube.

Mode of operation

If the CDC valve is not energised, the valve gate and cylinder are fixed in the position illustrated by the spring forces. In this position, damper oil can drain through a defined port cross section from the piston chamber to the equalising chamber (=medium damping forces).

The armature is shifted by applying current to the magnetic coil. Thus, the port cross sections for the damper oil change. Large cross-sections, and hence low damping forces, are achieved at low activation currents (as of approx. 600 mA). High damping forces are set when the damper is activated by applying a high current (from approx. 1000 mA to approx. 2000 mA).

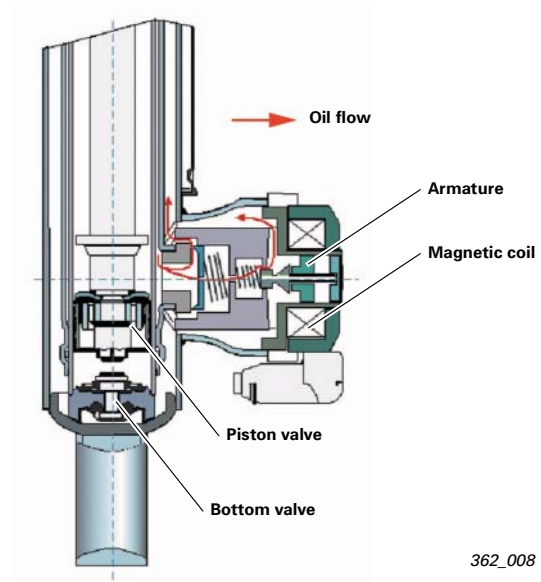

362_008

Note



In the event of a system fault, the valve is deenergised. Thus, medium damping forces are set and the vehicle maintains driving stability.

System components

Air suspension damper CDC valve

The air supply unit together with the valve block is attached to a common mounting bracket on the vehicle floorpan at the front right. The design and mode of operation of the air suspension damper CDC valve are identical to the unit used in the VW Touareg. The Q7 does not have a tyre inflation connection.

The maximum system pressure is 16.5 bar. The maximum operating time of the compressor is determined by its temperature, which is monitored permanently by a sender, like in the A6 and A8.

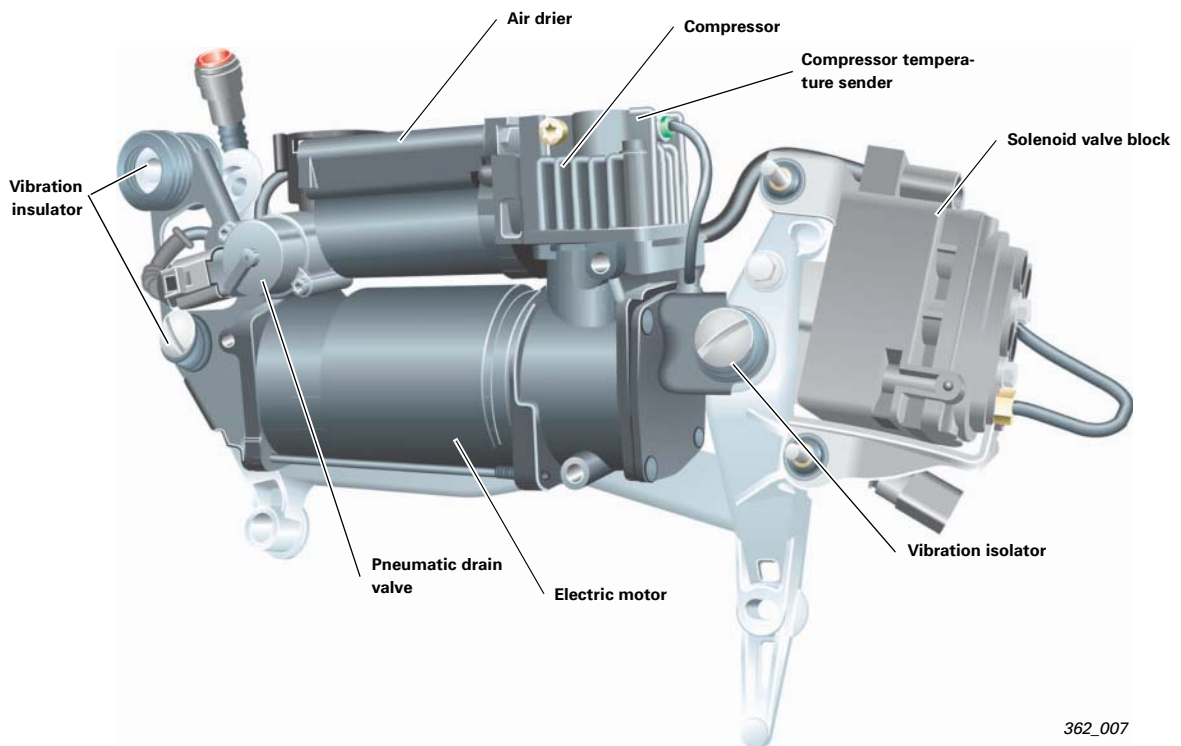

adaptive air suspension (aas)

System components

Pressure accumulators

The pressure accumulators have the following functions:

- Implementation of control actions (raising the vehicle level) without activating the compressor, thereby improving the quality of the interior acoustics, reducing the compressor temperature and increasing the availability of the compressor function.
- Vehicle level correction after occupants exit the vehicle, after 2, 5 and 10 hours depending on requirements.
- Due to much greater air volume in the system, two pressure accumulators are used in the Q7, instead of one like in the A6 and A8.

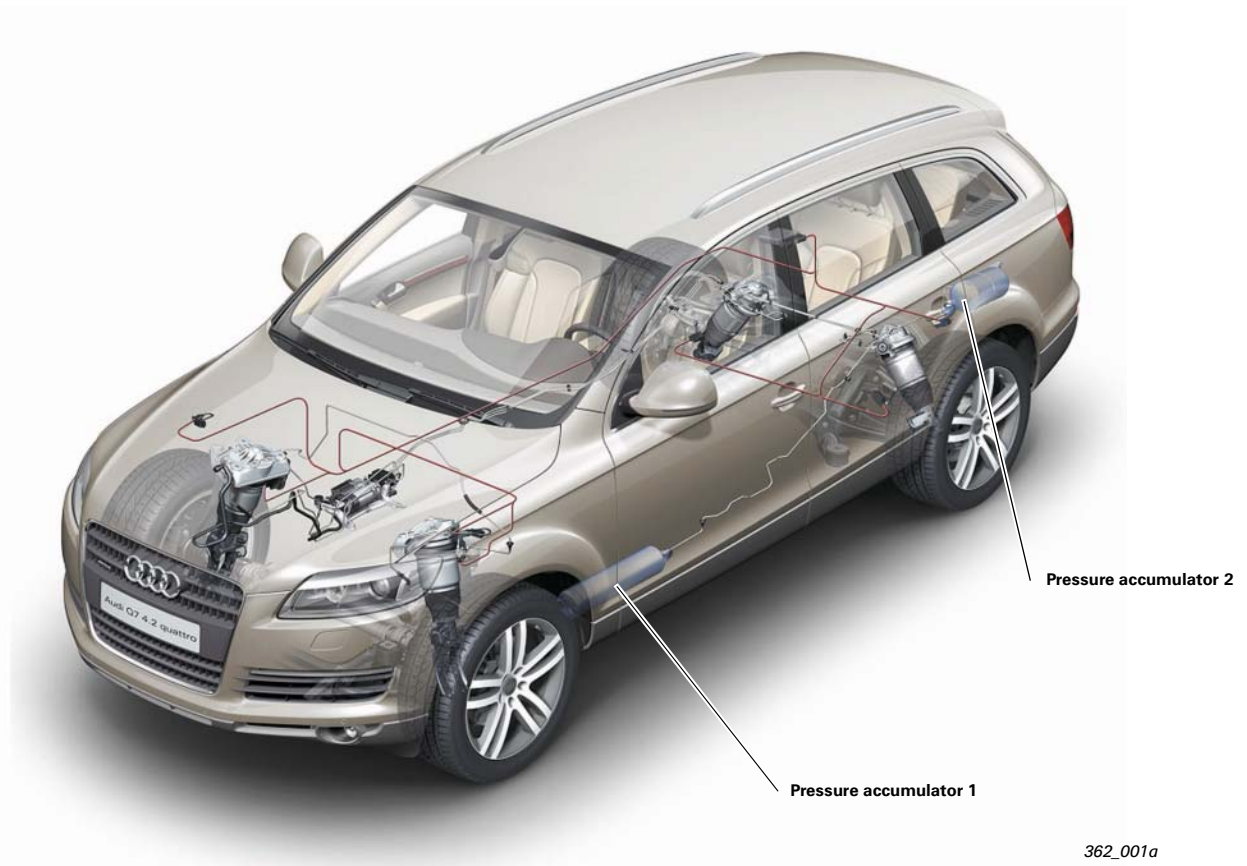

The pressure accumulator is made of aluminium. The storage volumes of the front/rear accumulators are 5.2l / 4.8 l. A control operation can only be performed with the accumulator if the air pressure in the accumulator is 3 bar greater than the air pressure in the participating air spring.

If the air pressure in the pressure accumulator drops to approximately 12.3 bar while the system is active and with the vehicle's engine running and the vehicle travelling at a speed of greater than 35 kph, the compressor starts up and charges the accumulator.

System components

Sensors

The vehicle level and the acceleration of the unsprung masses are measured by the vehicle level sender, like in the A8 and A6.

The senders are identical to those used in the A8 and VW Touareg.



Like in the A8 and A6, the body acceleration sender are used to measure vehicle body acceleration (acceleration of the sprung masses). The senders are identical to those used in the A8 and VW Touareg.

Two senders are installed in the wheel arches at the right left and right. A third sender is located in the vehicle interior at the rear left, at rear axle level.

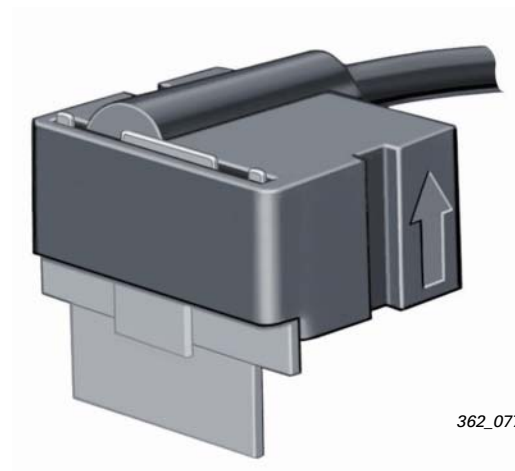

adaptive air suspension (aas)

Vehicle ride heights

"automatic" mode

In this mode, the vehicle is in its basic position. The shock absorber setup is a compromise between comfortable and sporty, and therefore is ideal for handling most driving situations on paved roads.

"comfort" mode

The vehicle is in its basic position; the shock absorber setup is comfort-oriented.



362_015

"lift" mode

The vehicle level is 60mm higher than in "automatic" mode, with the same spring and shock absorber setup as in "automatic" mode.

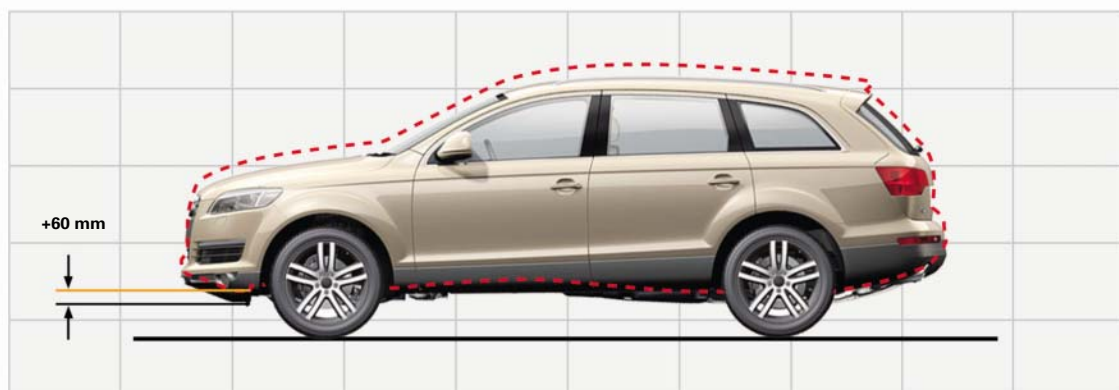

362_016

Vehicle ride heights

"offroad" mode

The vehicle level is 25mm higher than in "automatic" mode. A number of ESP functions for traction improvement (see under ESP) are activated automatically. This mode was developed specially for offroad use.

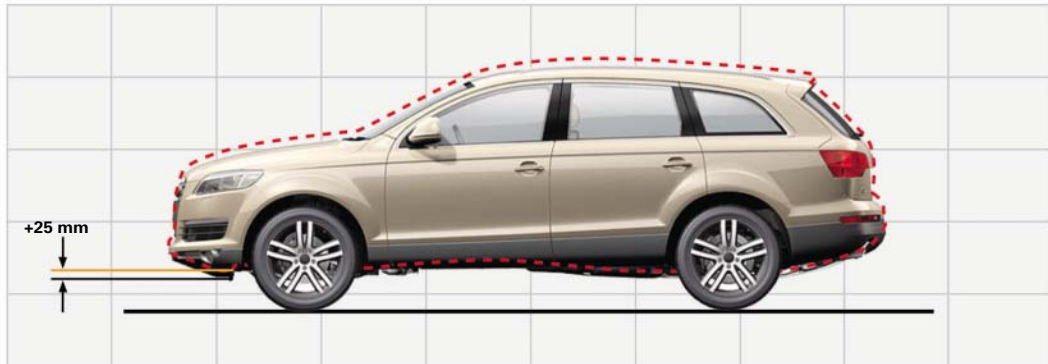

362_017

"dynamic" mode

The vehicle level is 15mm lower than in "automatic" mode . The damping control system is adapted for sporty handling.

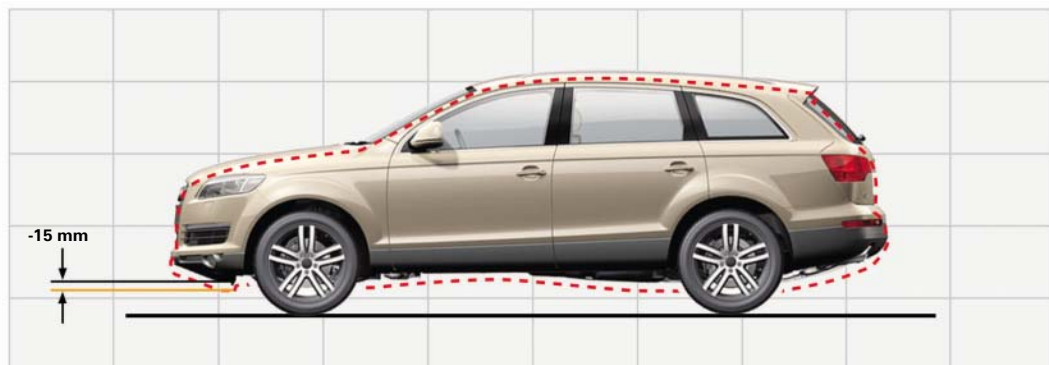

362_018

"Load" mode

For easier loading from an ergonomic viewpoint, the vehicle rear end is lowered at the rear axle by 45mm. It is not possible to drive the vehicle in this mode.



362_019

adaptive air suspension (aas)

Vehicle levels - modes

"Load" mode

The "Load" mode can be activated with the MMI or the button in the rear of the vehicle.

The function:

- can only be activated with the MMI if all doors are closed

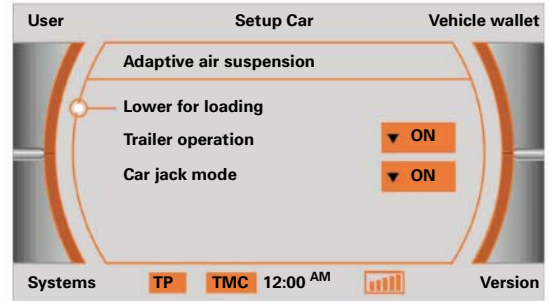

362_020

- can only be activated by button if all doors are closed and the tailgate is open

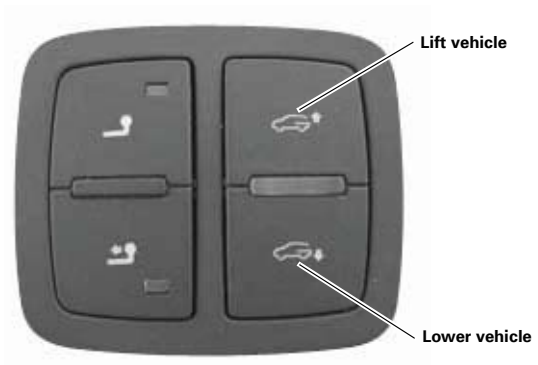

362_021

To illustrate the active "load" mode, the vehicle symbol is replaced by the symbol shown here.

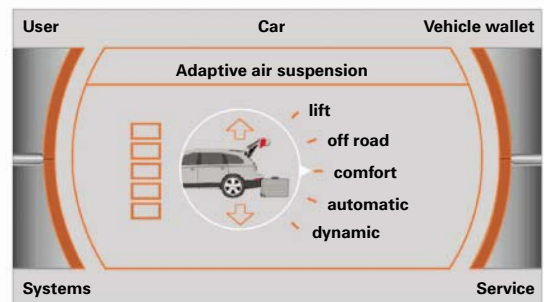

362_022

No bars are shown because the loading height is below the level which occurs during vehicle operation.

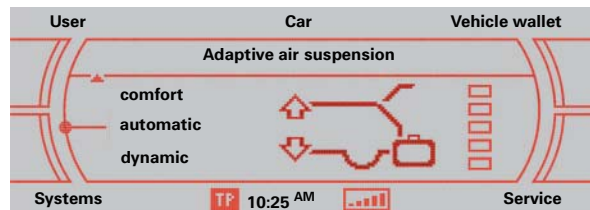

362_023

Control behaviour

Control behaviour without trailer operation

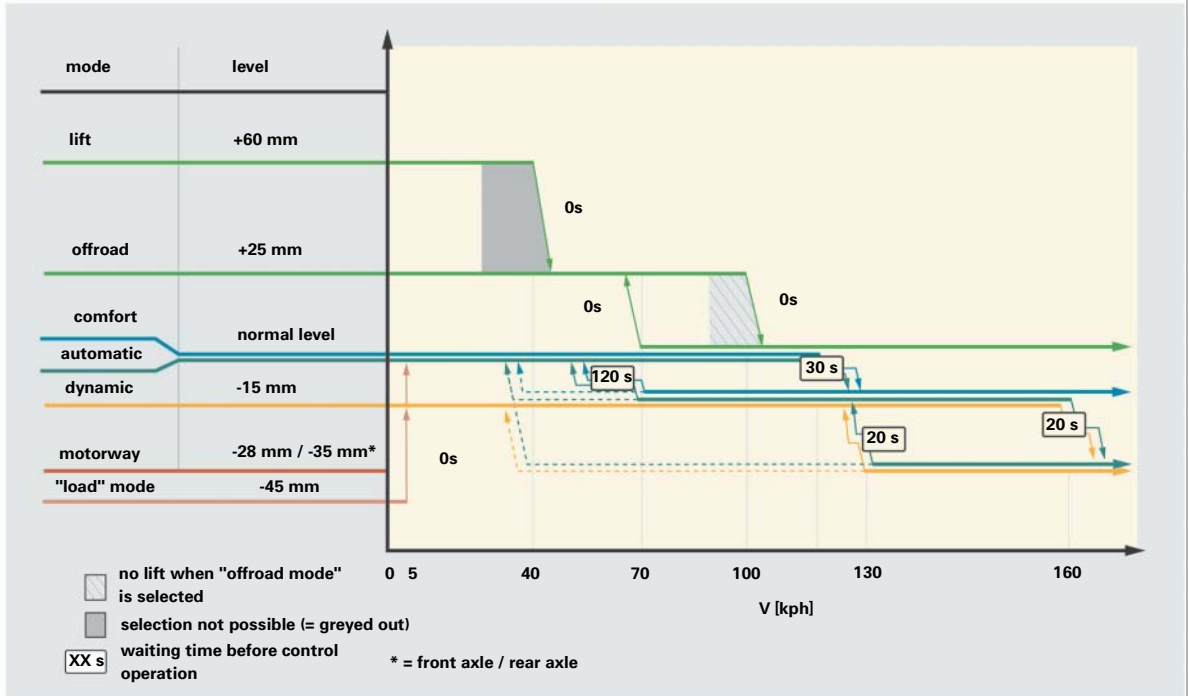

362_024

Control behaviour with trailer operation

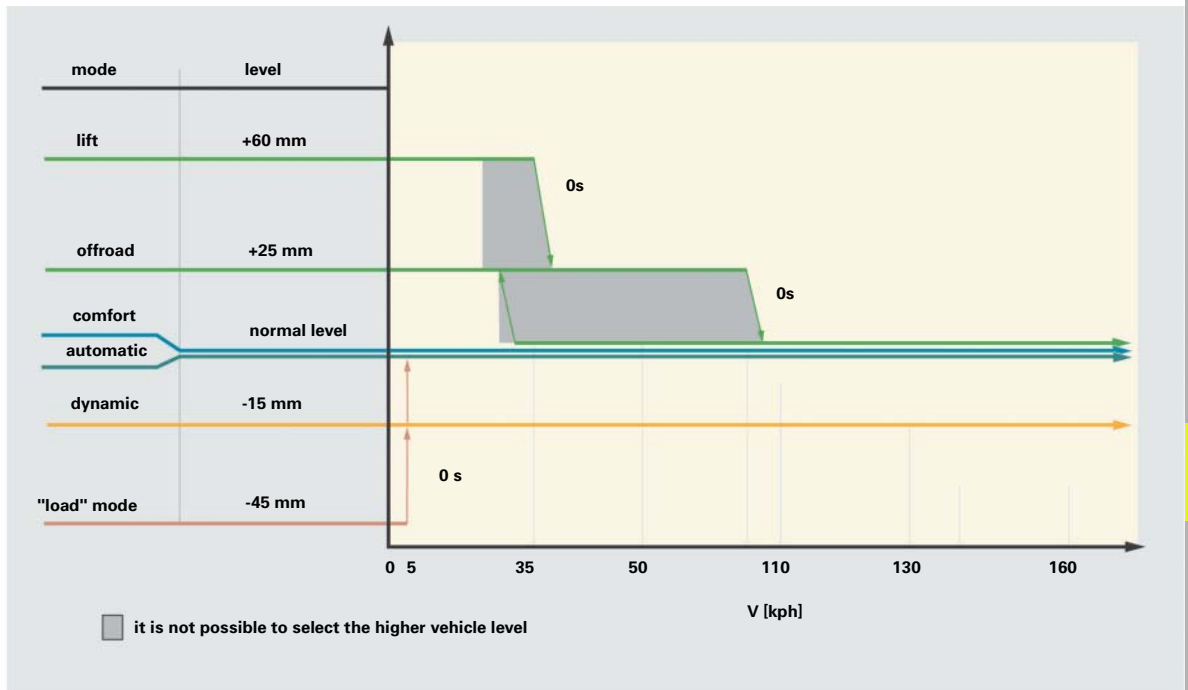

362_025

adaptive air suspension (aas)

Operation and displays

Like in the A8 and A6, the aas is operated using the CAR and SETUP buttons as well as the MMI control button.



362_026

A new component of the MMI display is the additional indicator bar on the left adjacent the vehicle icon. The indicator bar shows the vehicle's current ride level.

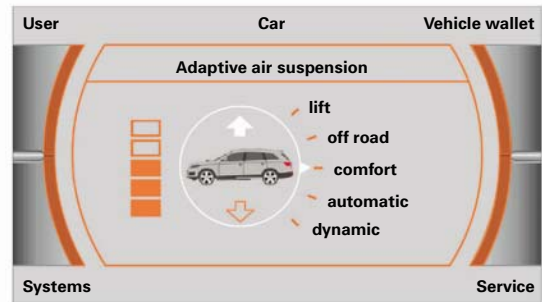

Display in vehicle equipped with MMI

362_027

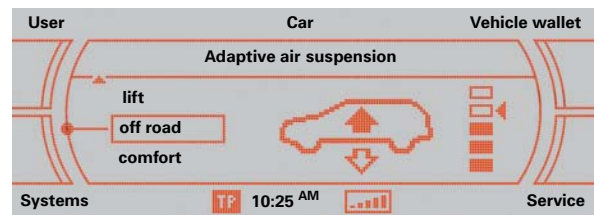

Display in vehicle equipped with MMI Basic

362_028

Operation and displays

A new feature is the temporary display in the centre display of the dash panel insert.

The indicator bar, the target marker and the control arrows are activated in the same way as on the MMI display.

This display can be selected manually with the Reset key on the wiper stalk.



Display in vehicle equipped with highline dash panel insert

362_029

Display is automatic when:

- **offroad** mode is selected
- **lift** mode is selected
- the car exits **lift** mode automatically when the speed threshold is exceeded

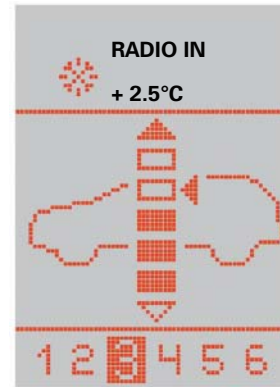

Display in vehicle equipped with midline and lowline dash panel insert

362_030

Like in the A8 and A6, there are two warning lamps in the dash panel insert. The following states are indicated:

Yellow warning lamp (continuous):

- in load mode
- in car jack mode (ride height control deactivated)
- in the event of system faults
- vehicle level extremely high (as of 80mm above normal level, warning lamp flashes)
- during final control test and basic adjustment in service workshop

Green lamp:

- loading height activated
- dynamic driving mode was selected (display duration: approx. 15 s)
- extreme payload from 25mm below normal level (except in "dynamic" mode)

Both lamps (flashing):

- vehicle under extreme load (from 65mm below normal level)



362_031

adaptive air suspension (aas)

Function diagram

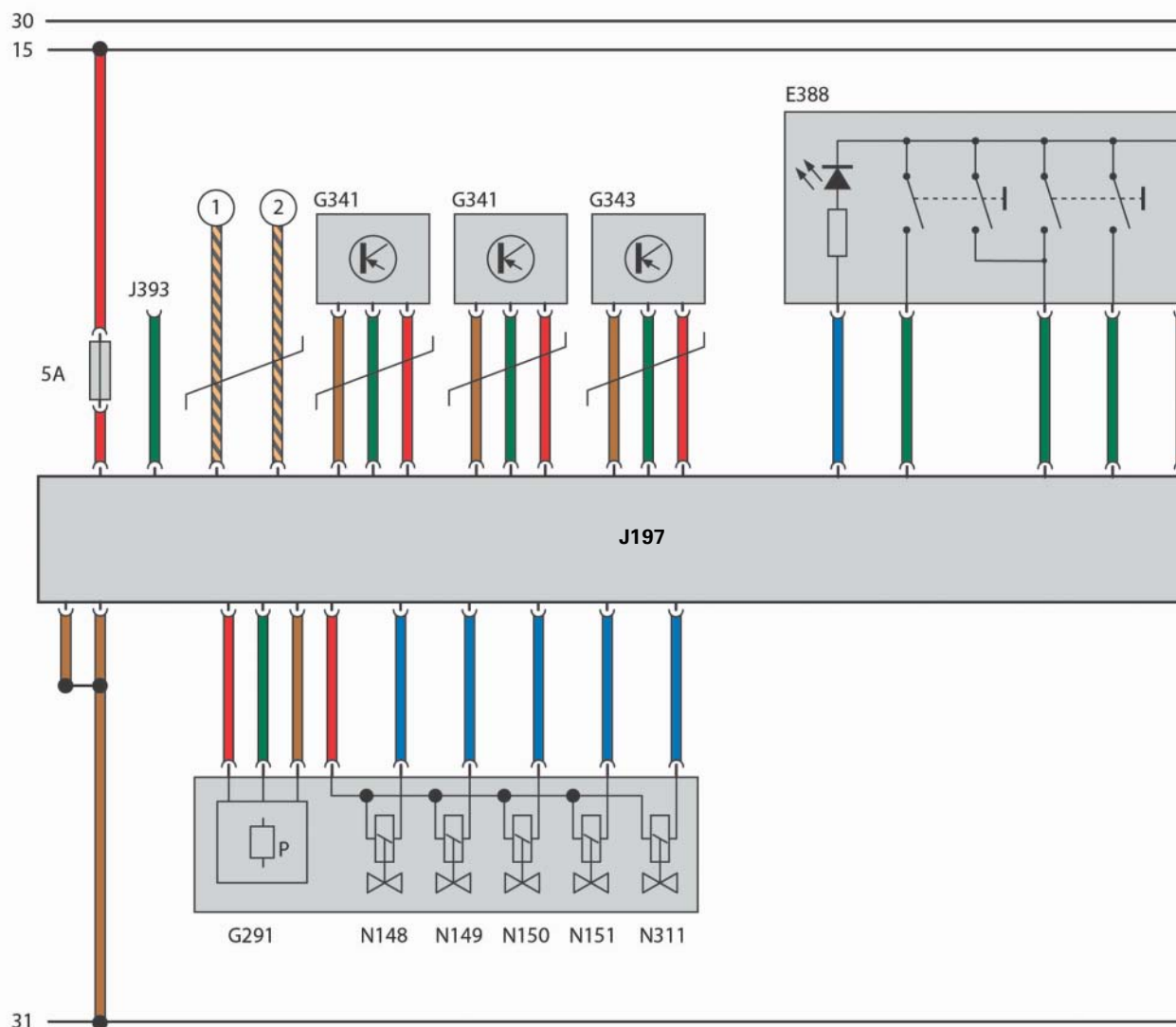

J197 Adaptive suspension control unit
 G76 Vehicle level sender, rear left
 G77 Vehicle level sender, rear right
 G78 Vehicle level sender, front left
 G289 Vehicle level sender, front right
 G290 Compressor temperature sender
 G291 Adaptive suspension pressure sender
 J393 Convenience system central control unit
 (for doors signal)
 G341 Body acceleration sender, front left
 G342 Body acceleration sender, front right
 G343 Body acceleration sender, rear
 J403 Adaptive suspension compressor relay
 N111 Adaptive suspension drain valve
 N148 Suspension strut valve, front left
 N149 Suspension strut valve, front right
 N150 Suspension strut valve, rear left
 N151 Suspension strut valve, rear right

N311 Adaptive suspension pressure accumulator valve
 N336 Damper adjustment valve, front left
 N337 Damper adjustment valve, front right
 N338 Damper adjustment valve, rear left
 N339 Damper adjustment valve, rear right
 V66 Adaptive suspension compressor motor
 E388 Adaptive suspension button

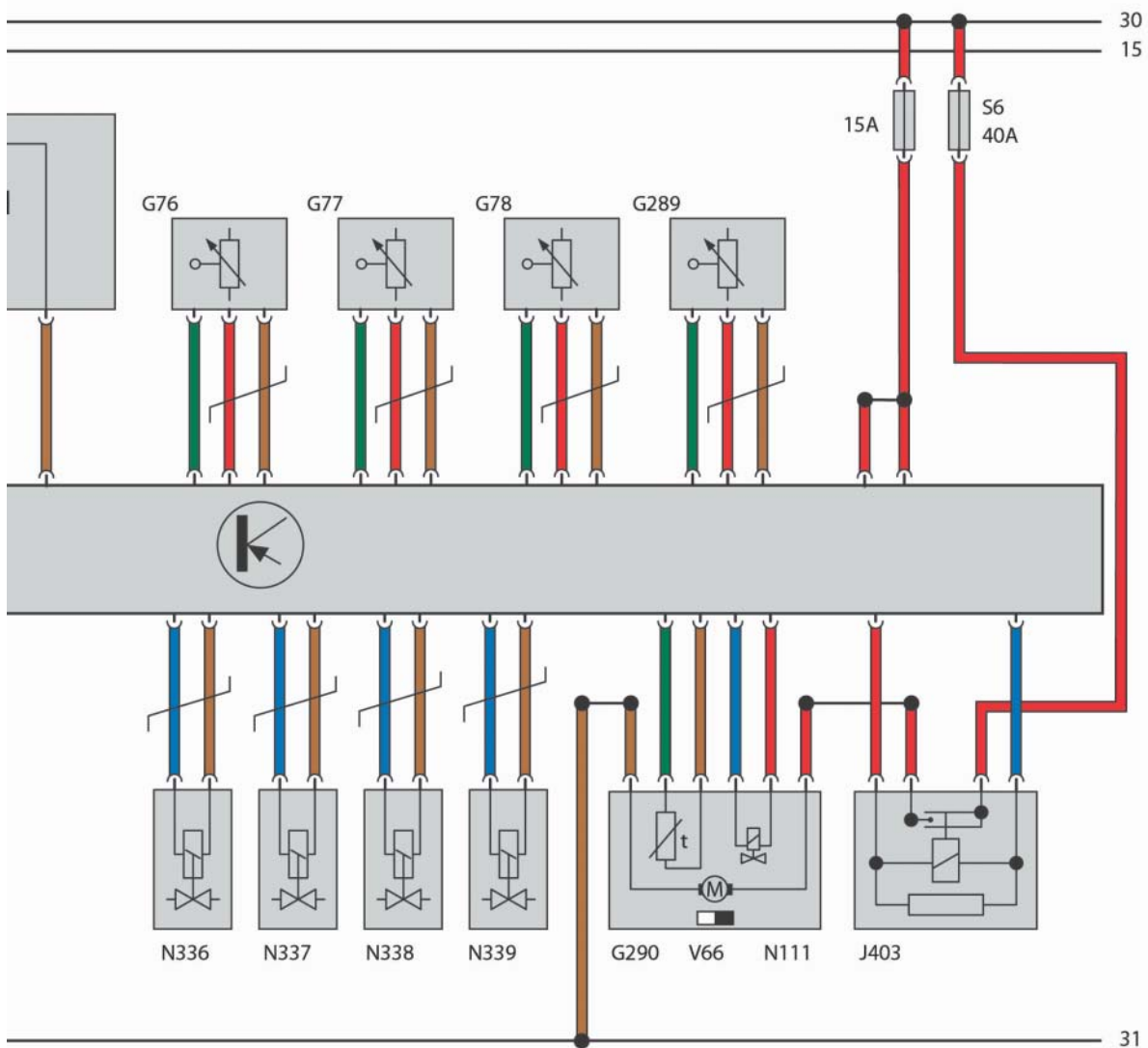

362_033

Colour codes

- Input signal
- Output signal
- Positive supply
- Earth
- CAN bus

① CAN-High

② CAN-Low

adaptive air suspension (aas)

CAN information exchange

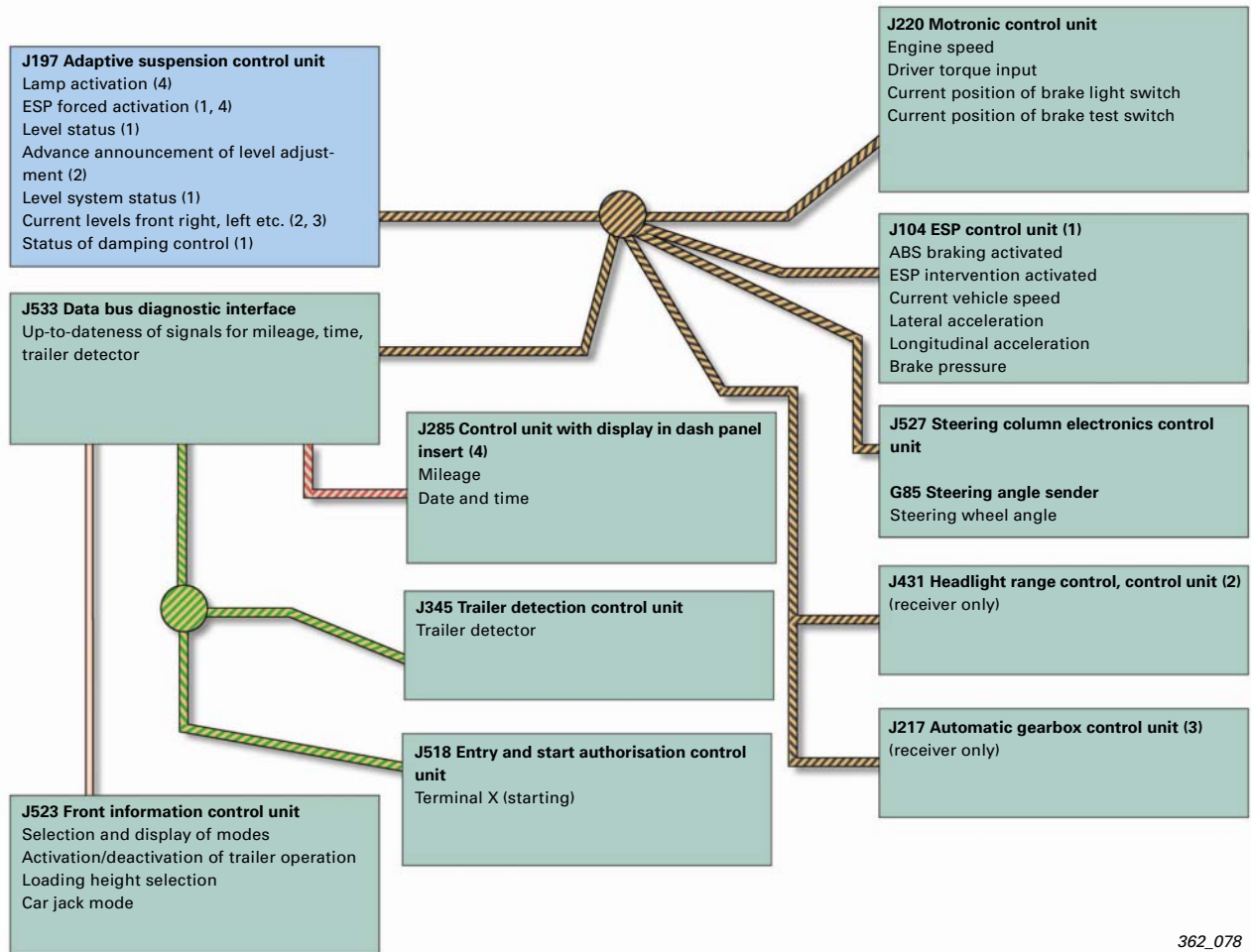

362_078

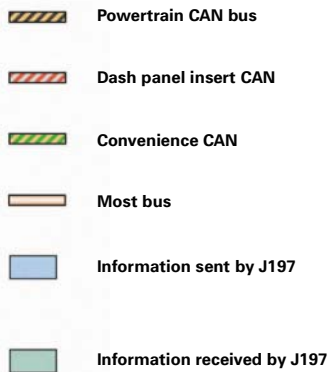

Service work

New service procedures:

1. Encoding control unit J197:

When a control unit is replaced or flashed, it must initially be encoded before a system initialisation can be performed.

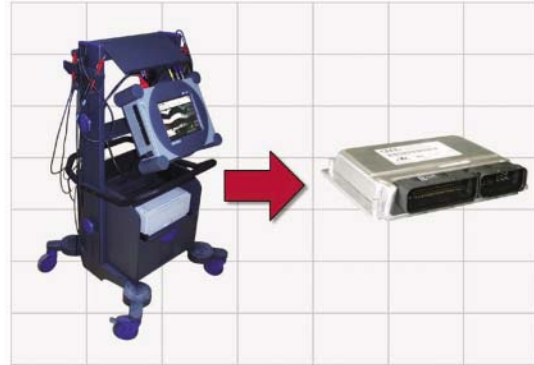

362_068

2. Final control test:

The pressure accumulator test is now performed; temperature and pressure gauge readings are displayed. The warning lamps are no longer activated.

3. System initialisation:

The vehicle ride heights are adapted in a modified procedure.



362_067

All rights reserved.
Technical specifications
subject to change without
notice.

Copyright
AUDI AG
I/VK-35
Service.training@audi.de
Fax +49-841/89-36367

AUDI AG
D-85045 IngoIstadt
Technical status: 11/05

Printed in Germany
A05.5S00.15.20