



Protected by copyright. Copying for private or commercial purposes, in part or in whole, is not permitted unless authorised by AUDI AG. AUDI AG does not guarantee or accept any liability with respect to the correctness of information in this document. Copyright by AUDI AG.



adaptive air suspension in the Audi A8

Home study program 292

The development of the running gear is subject to conflicting objectives. For now, besides "classic" aims such as function, driving safety, strength and durability, requirements such as weight reduction, driving comfort and acoustics are increasingly gaining in importance.

At first glance, many requirements appear to be in mutual opposition. A car designed to be very comfortable will lose out in terms of driving safety when driven at the limit.

On the other hand, a car with very sporty tuning will achieve considerably higher cornering speeds, and will reach its limit much later. However, this sporty tuning necessarily entails limitations when it comes to comfort.

In the Audi A8 MY 2003, a newly developed, fully bearing air suspension system is used. In conjunction with the CDC status-dependent electronic damping control, this ensures that the main - and partly conflicting - requirements are satisfied in an optimum manner within the limits of the laws of physics.

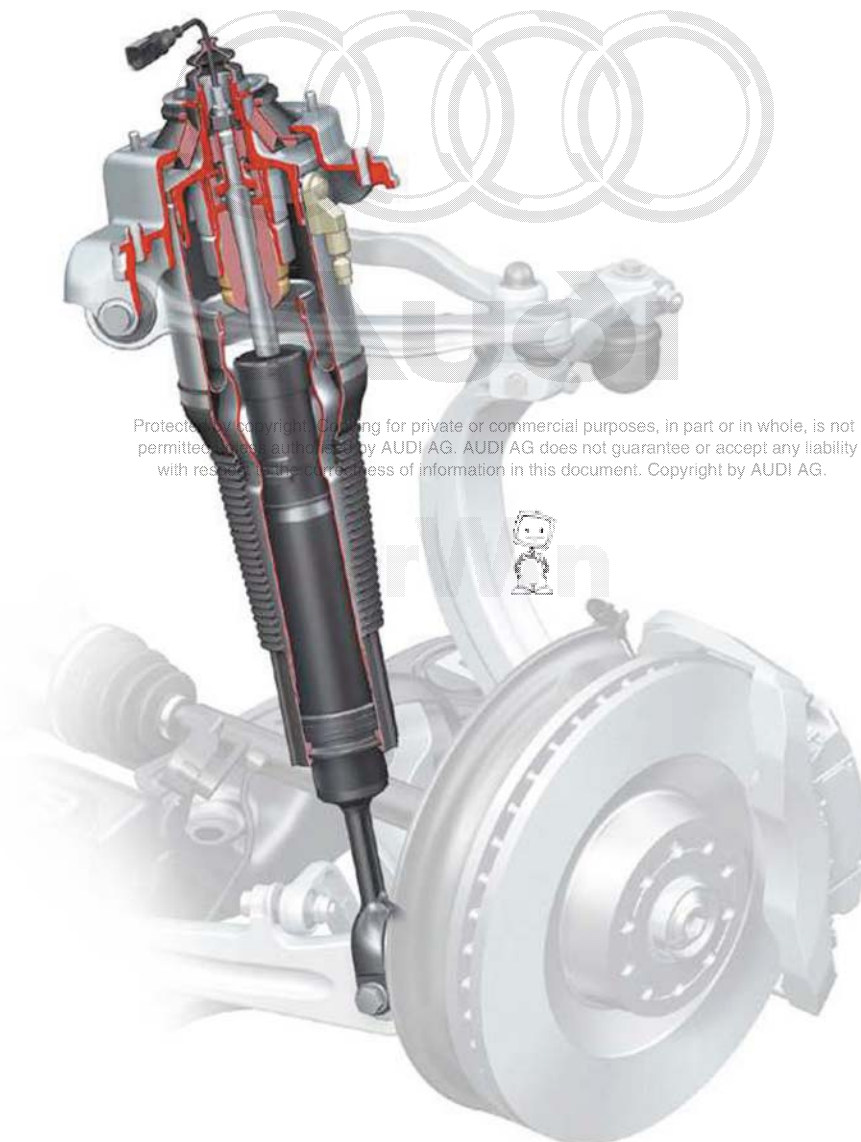

	Page
Introduction	
Basics	4
New technology	4
Operation and display	
Vehicle levels	6
Operation and display system	9
System components	
Vehicle overview	10
Control unit J197	12
Suspension/shock absorber strut	13
Shock absorber	14
Air supply unit	15
Solenoid valve block	16
Accumulator	16
Pneumatic diagram	18
Pressure build-up	19
Pressure reduction	19
Senders (sensors)	20
System functions	
Control concept for standard running gear	26
Control concept for sporty running gear	28
Control concept for special operating conditions	29
Interfaces	
System overview of components with bus link (CAN, MOST)	34
System overview of components without bus link	35
CAN information exchange	36
Function diagram	38
Other interfaces	40
Service	
Control unit code	42
System initialisation	42
Final control diagnosis	43
Measured value blocks	43

The home study program informs you about designs and functions.

The home study program is not a Repair Manual!
All values stated herein are purely intended to facilitate your understanding of the program, and are based on the software version valid at the time the SSP was compiled.

For service and repair work, it is important that you please use the current technical literature.

New!



Caution! Note!



Introduction



Basics

The basics for understanding air suspension systems are contained in home study programs 242 and 243 and are of course also valid for the system to be introduced in the A8 from model year 2003.

New technology

The new A8 heralds a new system in terms of technical content and range of functions. It differs from the known system of the allroad quattro in the following features:



292_001

CDC instead of PDC damping control:

The control takes account of the current driving status. The wheel movements (unsprung masses) and body movements (sprung masses) are recorded.

Within the choice of four programs (modes), different damping characteristics are implemented. In this process, each shock absorber can be controlled independently.

Therefore, in each mode which is selected (comfortable or sporty), the maximum degree of comfort and driving safety is ensured (see description "Shock absorber" in the "System components" section).

The term "mode" can therefore be understood to be the well-balanced combination of the adaptive air suspension program and the damping map.

Protected by copyright. Copying for private or commercial purposes, in part or in whole, is not permitted unless authorised by AUDI AG. AUDI AG does not guarantee or accept any liability with respect to the correctness of information in this document. Copyright by AUDI AG.

Enhanced sensor system:

Three acceleration sensors are employed to record the body movement. (See description "Body acceleration sender" in the "System components" section.)

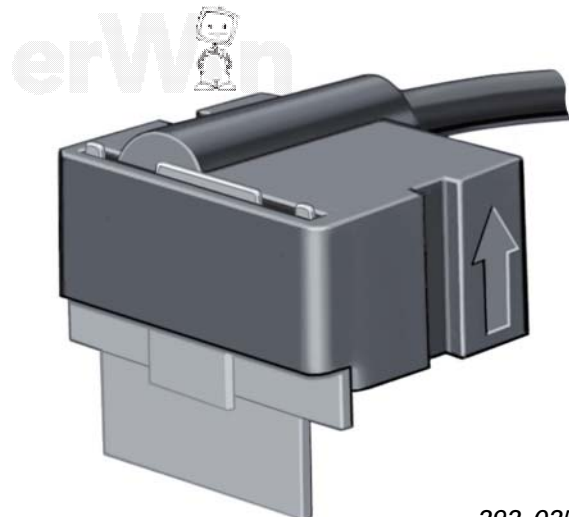

292_025



Encased pneumatic springs:

The air bellows are encased in an aluminium cylinder. The result is a considerable improvement in the response characteristic. (See description "Pneumatic springs" in the "System components" section.)



292_003

Operation:

Integration in the MMI means that operation is user-friendly, logical and easy to learn. (See description in the "Operation and display" section.)



292_002

Protected by copyright. Copying for private or commercial purposes, in part or in whole, is not permitted unless authorised by AUDI AG. AUDI AG does not guarantee or accept any liability with respect to the correctness of information in this document. Copyright by AUDI AG.

Residual pressure retaining valves:

Each suspension strut features residual pressure retaining valves directly at the air connection. This ensures that a minimum pressure of approx. 3.5 bar is maintained in the pneumatic springs. This practically eliminates the risk of damage during storage and assembly to the greatest possible extent.



Operation and display

Vehicle levels

The A8 comes either with a standard running gear (adaptive air suspension) or a sporty running gear (adaptive air suspension-sport).

Standard running gear:

The following programs can be selected either manually or automatically:

"automatic" mode:

Basic vehicle level, comfort-oriented suspension with appropriately adapted damper map. The vehicle is lowered by 25 mm after 30 seconds at speeds of 75 mph (120 km/h) or more ("motorway lowering"). This lowered position improves aerodynamics and reduces fuel consumption.

"comfort" mode:

Vehicle height as in "automatic" mode, less damping at lower speeds than in "automatic" mode, resulting in even greater driving comfort than in "automatic" mode. There is no automatic motorway lowering.

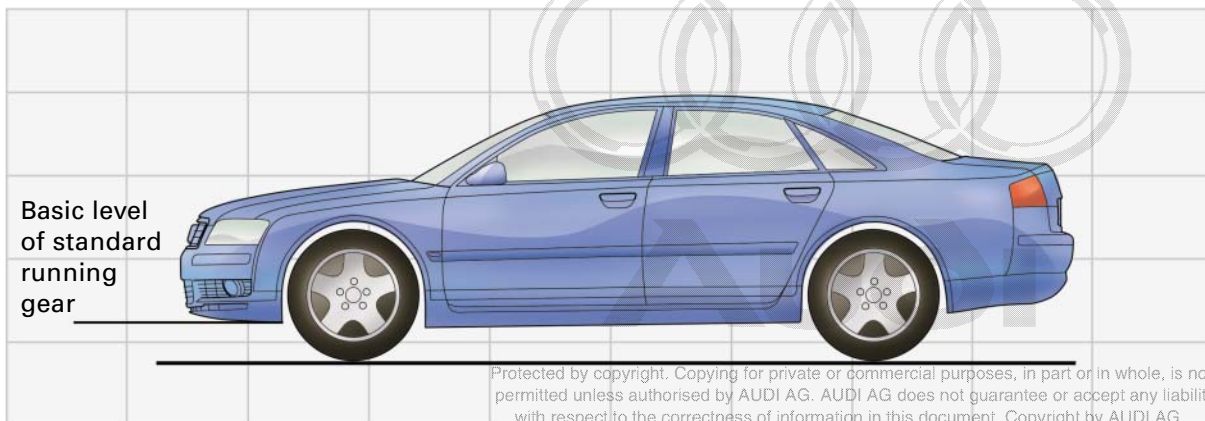

"automatic" and "comfort" mode: Basic level

292_005





"dynamic" mode:

Vehicle level is 20 mm lower than in "automatic" mode. The damper map is automatically set to sporty. After 30 seconds at speeds of 75 mph (120 km/h) or more, the car is lowered by another 5 mm ("motorway lowering").

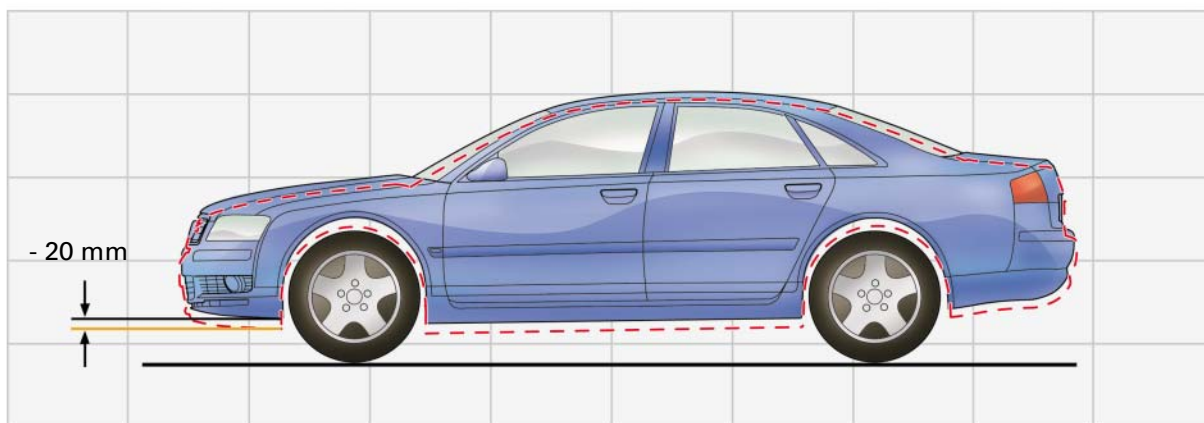

"dynamic" mode: - 20 mm

292_004

"lift" mode:

Vehicle level is 25 mm higher than in "automatic" mode, comfort-oriented suspension like "automatic" mode.

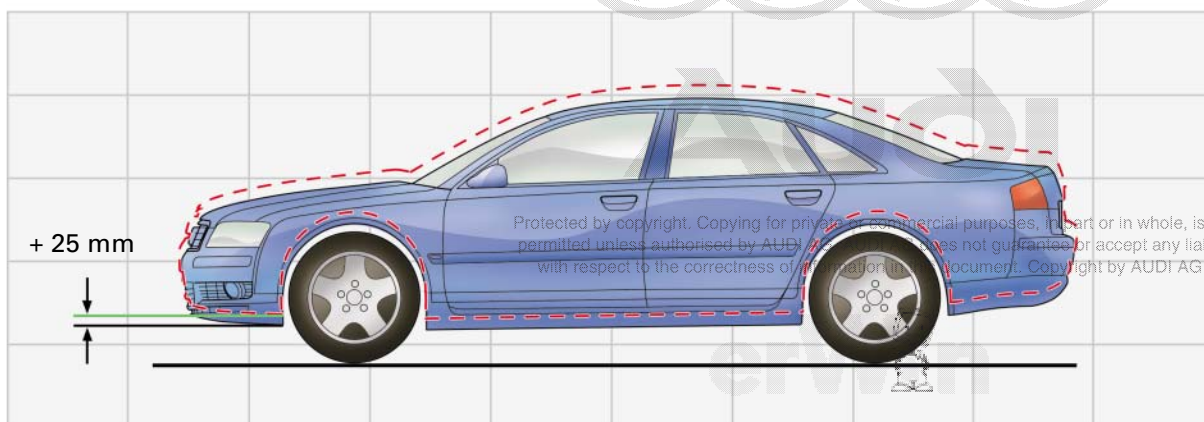

"lift" mode: + 25 mm

292_006

Operation and display

Sporty running gear:

"automatic" mode:

Basic vehicle level corresponds to "dynamic" mode in the standard running gear, sporty suspension with appropriately adapted damper map (more comfortable than "dynamic" mode). The vehicle is lowered by another 5 mm after 30 seconds at speeds of 75 mph (120 km/h) or more ("motorway lowering").

"dynamic" mode:

Level as for "automatic" mode of sporty running gear, hard, sporty suspension with appropriately adapted damper map. The vehicle is lowered by 5 mm after 30 seconds at speeds of 75 mph (120 km/h) or more ("motorway lowering").

"comfort" mode:

Level as for "automatic" mode of sporty running gear, less damping at lower speeds than in "automatic" mode. There is no automatic motorway lowering.

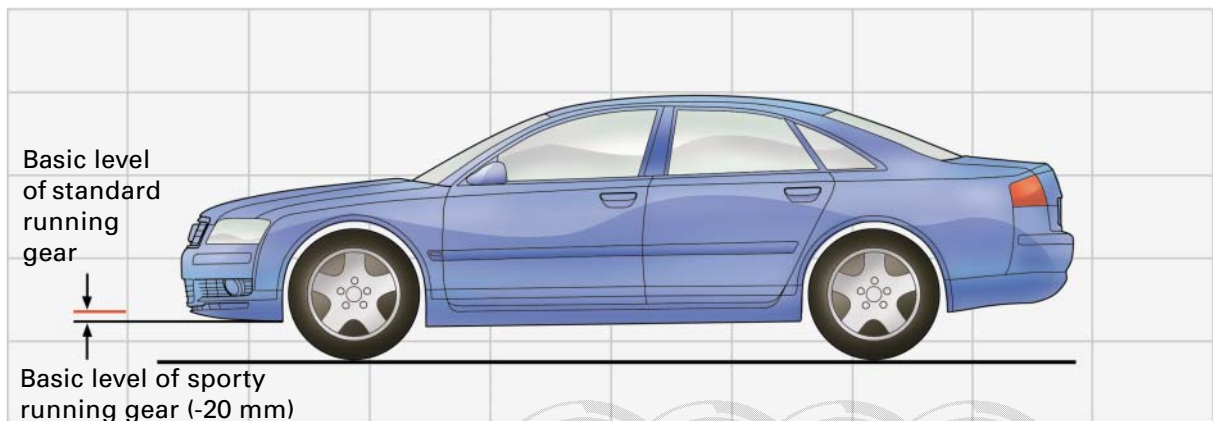

"dynamic", "automatic" and "comfort" mode: Basic level for sporty running gear 292_049

"lift" mode:

Level 25 mm higher than "automatic" mode of sporty running gear, sporty suspension.

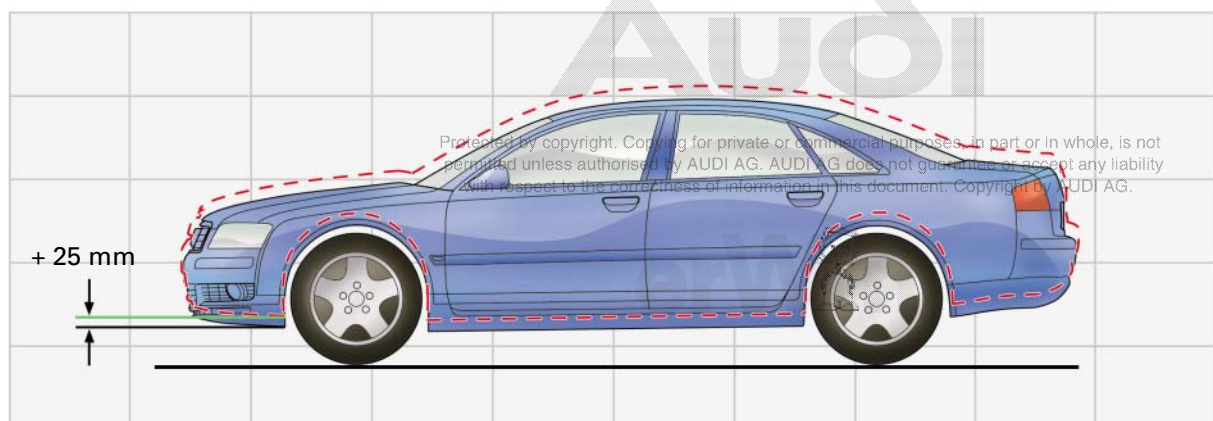

"lift" mode: + 25 mm

292_006

Operation and display system

The process of switching from one mode to another and the display/monitoring of the system status all form part of the MMI operating system.

The adaptive air suspension menu is opened directly in the MMI display in the centre console when the "CAR" button is pressed. This ensures that adaptive air suspension has first priority. This means that any other functions already in the display are blanked out in favour of the adaptive air suspension operating/status display.

Turning the control knob to a different mode and then pressing the control knob activates a new mode.

System status information can be requested and special settings undertaken by pressing the SETUP button.

(See current Owner's Manual and "Control strategy" in the "Special system states" section.)



292_010

With the standard running gear, the "dynamic" mode (low level) is additionally displayed as driver information by an indicator lamp in the dash panel insert.

An extremely low or extremely high level is displayed by the indicator lamp and the warning lamp in the dash panel insert.

(See "Control strategy" in "Special system states".)



Warning lamp

Indicator lamp for extreme low level

292_011

Protected by copyright. Copying for private or commercial purposes, in part or in whole, is not permitted unless authorised by AUDI AG. AUDI AG does not guarantee or accept any liability with respect to the correctness of information.

erWin

System components

Vehicle overview

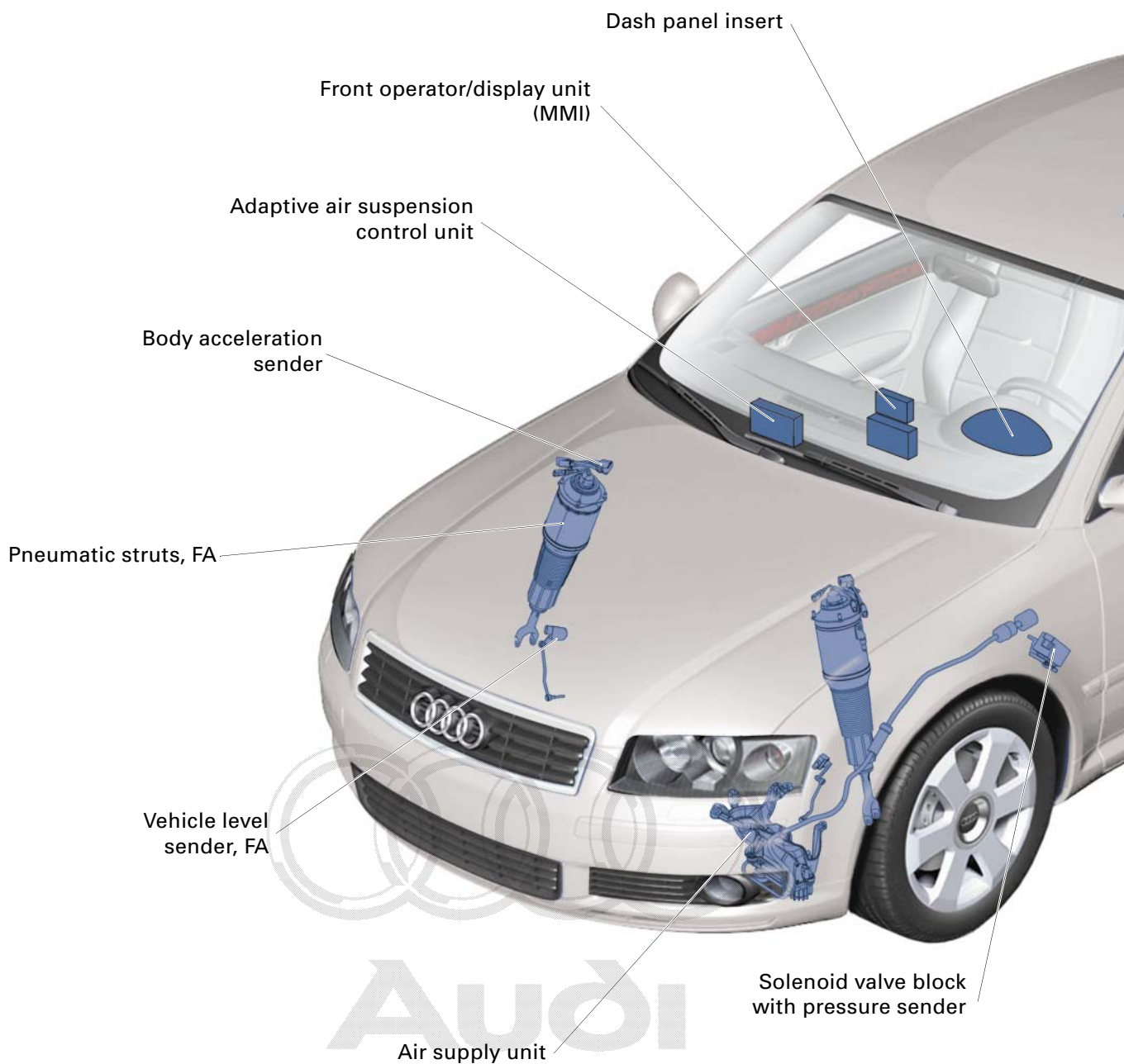
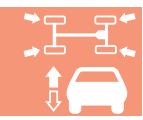

Protected by copyright. Copying for private or commercial purposes, in part or in whole, is not permitted unless authorised by AUDI AG. AUDI AG does not guarantee or accept any liability with respect to the correctness of information in this document. Copyright by AUDI AG.



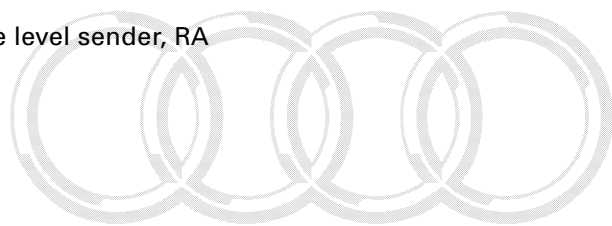
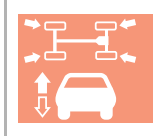
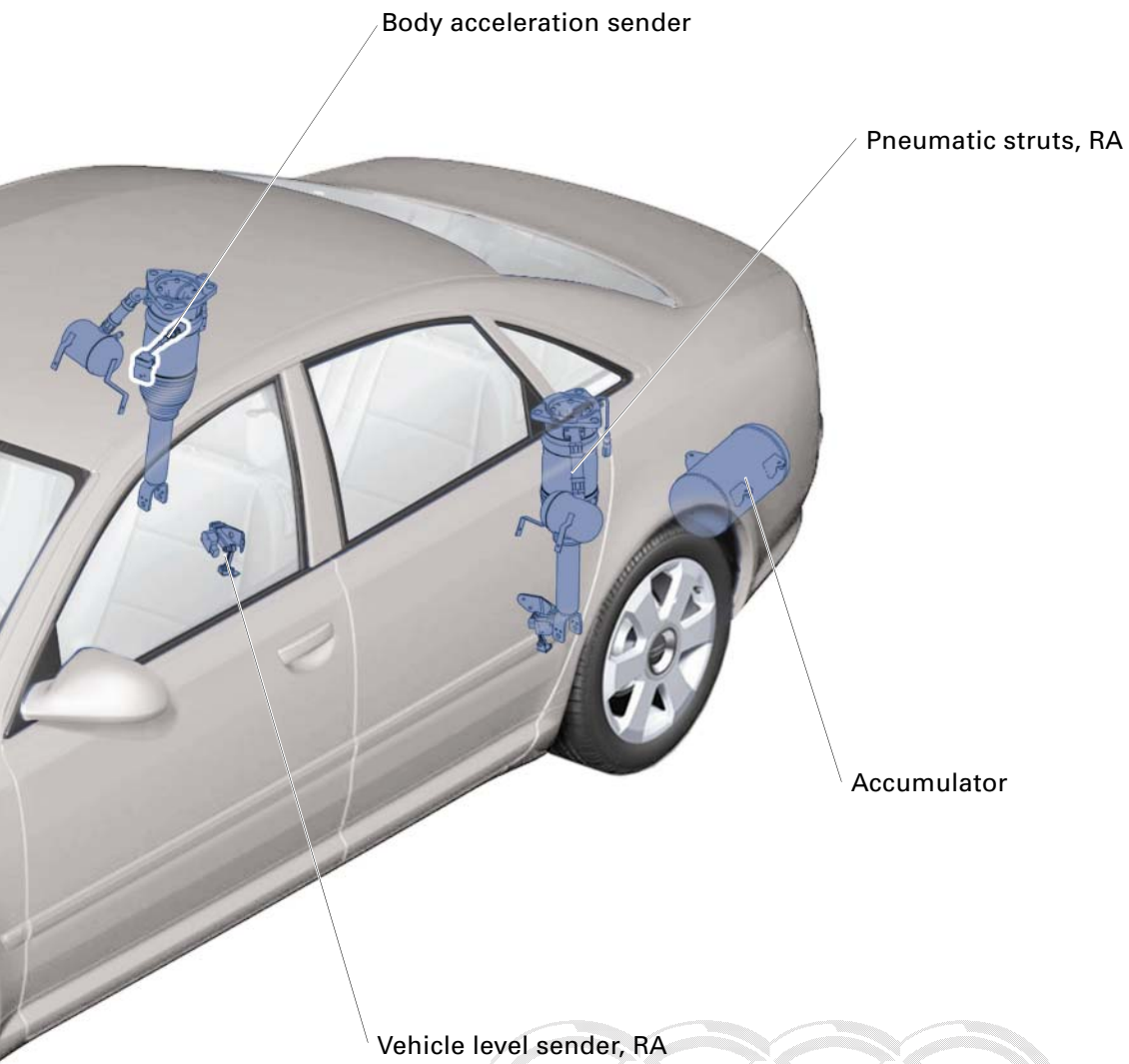

Audi
292_012

Protected by copyright. Copying for private or commercial purposes, in part or in whole, is not permitted unless authorised by AUDI AG. AUDI AG does not guarantee or accept any liability with respect to the correctness of information in this document. Copyright by AUDI AG.



System components

Control unit J197

The control unit is the central element of the system. It is installed in the vehicle in front of the glove box.

It processes the relevant messages from the other bus users, and the discreet input signals (see function diagram and CAN information exchange).

The principal result of this processing work are the signals to actuate the compressor, the solenoid valves and the shock absorbers.

Because of the differences between the standard and sporty running gears, the control unit had to be produced in two versions (software application).

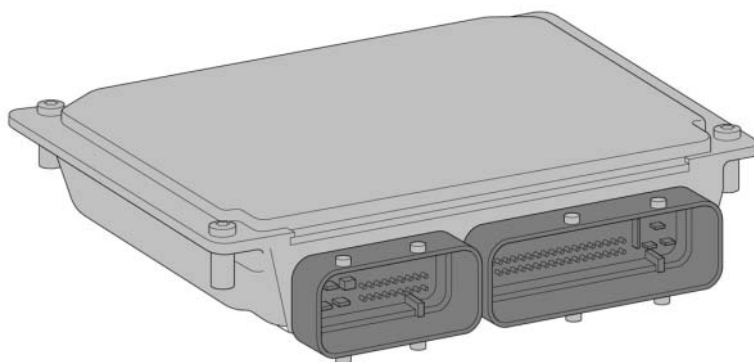
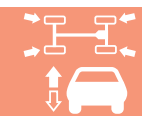

292_013

Hardware

4E0 907 553 C * = Standard running gear
4E0 907 553 D * = Sporty running gear

Software

4E0 910 553 C * = Standard running gear
4E0 910 553 D * = Sporty running gear



* These numbers are correct as at 06/2002. Changes may be made as a result of further technical developments.
(See current Repair Manual.)

Protected by copyright. Copying for private or commercial purposes, in part or in whole, is not permitted unless authorised by AUDI AG. AUDI AG does not guarantee or accept any liability with respect to the correctness of information in this document. Copyright by AUDI AG.



Suspension/shock absorber strut

All four suspension/shock absorber struts are constructed in the same way.

Pneumatic spring

Construction:

The pneumatic spring is encased in an aluminium cylinder. In order to prevent dirt from getting between the cylinder and the air bellows, the area between the piston and the cylinder is sealed by a sleeve. The sleeve can be replaced during servicing, but the air bellows cannot be replaced separately. In the event of a fault, the entire suspension/shock absorber strut must be replaced.

In order to provide as much usable space and loading width in the boot as possible, the diameter of the rear axle pneumatic springs is kept to a minimum. However, if demands for comfort are to be met, a minimum air volume is required. The solution to this conflict is provided in the form of a reservoir for additional air, which is connected to the shock absorber.

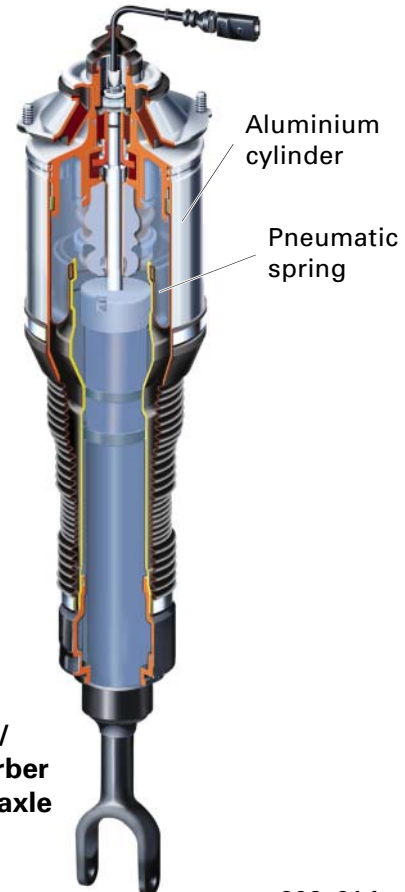

Suspension/
shock absorber
strut, front axle

292_014

Function:

The pneumatic spring not only replaces the steel spring, it also offers considerable advantages over the steel version (see SSP 242). Encasing the pneumatic spring in an aluminium cylinder enables the wall thickness of the bellows to be reduced. This results in an even more sensitive response to bumpy roads.



Suspension/
shock absorber
strut, rear axle

292_015

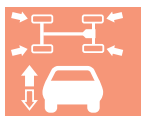

Protected by copyright. Copying for private or commercial purposes, in part or in whole, is not permitted unless authorised by AUDI AG. AUDI AG does not guarantee or accept any liability in respect to the correctness of information in this document. Copyright by AUDI AG.



System components

Shock absorber

Construction:

A twin-tube gas-filled shock absorber with continuous electrical control is used (continuous damping control = CDC shock absorber). The main damping valve 3 in the piston 1 is mechanically pre-tensioned by a spring 4. A solenoid 5 is situated above the valve, and the connecting cable is routed to the outside through the hollow piston rod.

Function:

For general information on the function of a twin-tube gas-filled shock absorber, see SSP 242.

The damping force is determined to a considerable extent by the flow resistance of the valves. The greater the flow resistance for the oil flowing through the valves, the higher the damping force.

Basic method of operation using bump as an example (= bump absorption):

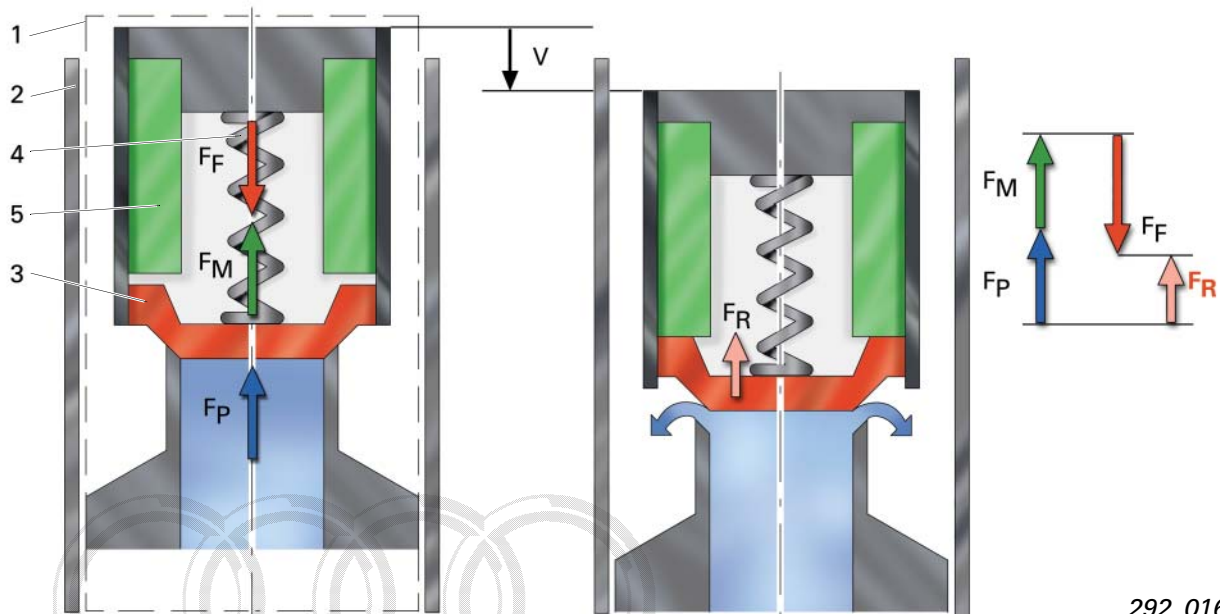

The entire piston unit 1 is moved downwards inside the cylinder tube 2 at speed v . The oil pressure in the chamber below the main damping valve 3 increases. Current flows to the solenoid 5. The magnetic force F_M counteracts the spring force F_F and partially raises it.

If the sum of the magnetic force and the oil pressure force ($F_M + F_P$) exceeds the spring force F_F , the resulting force F_R opens the valve. The amount of magnetic force can be regulated by adjusting the amount of electrical current. The higher the electrical current, the lower the flow resistance and thus the damping force.

Protected by copyright. Copying for private or commercial purposes, in part or in full, is not permitted unless authorised by AUDI AG. AUDI AG does not guarantee or accept any liability with respect to the correctness of information in this document. Copyright by AUDI AG.

Info: The highest damping force is achieved when the solenoid is not electrically actuated. For the lowest damping force, the solenoid must be receiving a current of approx. 1800 mA.

In emergency running mode, the solenoid is not electrically actuated. In this way, the damping force is set to maximum, ensuring a dynamically stable driving condition.

Air supply unit

The air supply unit is installed at the front left of the engine compartment. This prevents any impairment of the acoustics in the passenger compartment. Furthermore, more effective cooling can be achieved. This increases the amount of time the compressor can be switched on, and thus the quality of control.

Design:

The air supply unit is the same as the one used in the allroad quattro (see SSP 243).

Function:

It functions in an identical manner to the unit used in the allroad quattro.

The unit is switched off when necessary to prevent the compressor from overheating (excessive cylinder head temperature). The maximum static system pressure is 16 bar.

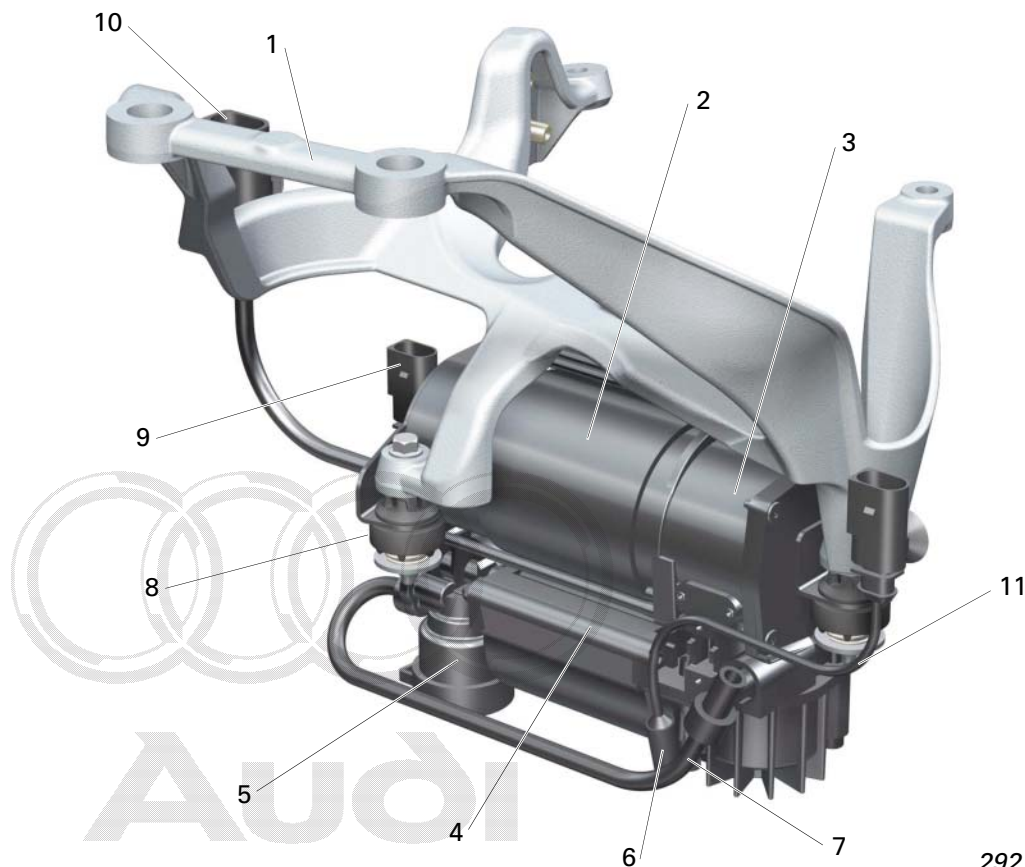
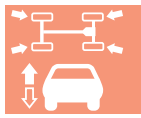

292_017

Protected by copyright. Copying for private or commercial purposes, in part or in whole, is not permitted unless authorised by AUDI AG. AUDI AG does not guarantee or accept any liability with respect to the correctness of information in this document. Copyright by AUDI AG.

Components:

1. Bracket
2. Electric motor
3. Compressor
4. Air drier
5. Pneumatic exhaust solenoid valve
6. Temperature sensor

Pneumatic connections:

7. Air intake and exhaust line
8. Compressed air connection to solenoid valve block

Electrical connections:

9. Connection to exhaust solenoid valve
10. Connection for battery voltage 12V
11. Connection for temperature sensor

System components

Solenoid valve block

The solenoid valve block contains the pressure sender and the valves for actuating the pneumatic springs and the accumulator. It is installed in the wheel housing between the wheel housing liner and the left-hand A-pillar.

Solenoid valves

Construction/function:

The construction and function of the solenoid valves are largely the same as in the allroad quattro (see SSP 243).

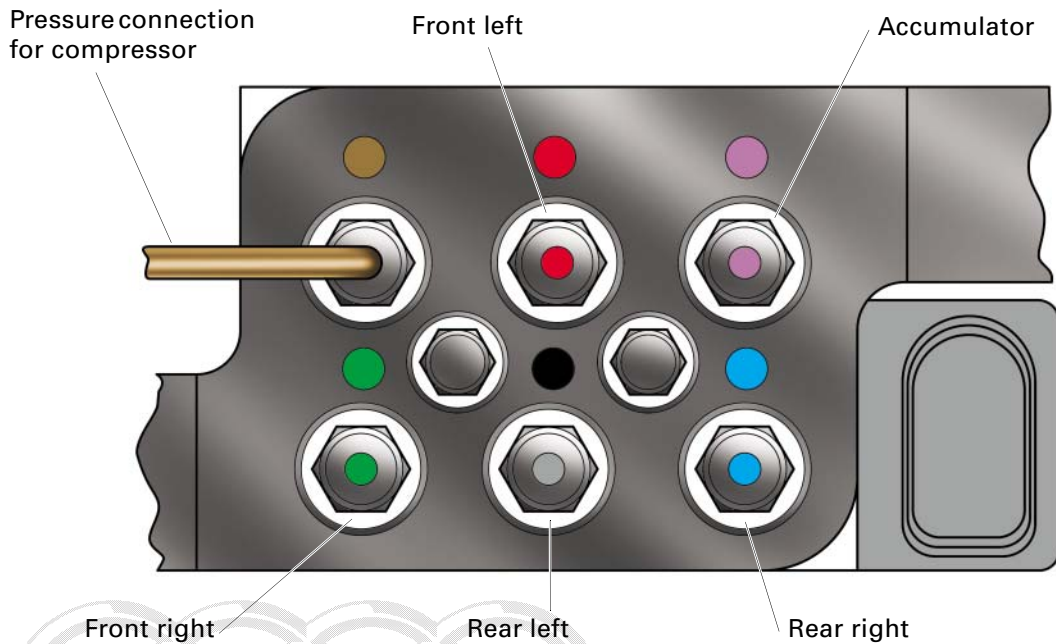

292_018

Accumulator

The accumulator is situated between the floor of the boot and the rear silencer on the left-hand side of the vehicle.

Construction:

The accumulator is made of aluminium.

It has a volume of 5.8l and a max. operating pressure of 16 bar.

Function:

The objective in designing this system was to reliably satisfy functional requirements whilst keeping energy consumption to a minimum (so that the compressor is on as little as possible). In order to enable controlled pressure build-up to be effected solely with the accumulator, there must be a minimum difference in pressure of 3 bar between the accumulator and the pneumatic springs.

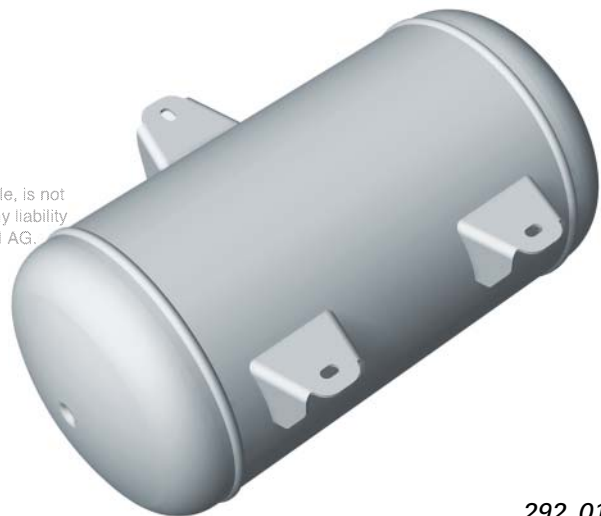

292_019

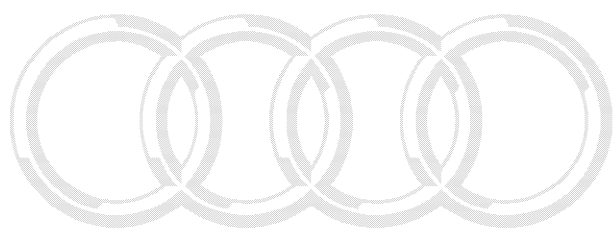

Audi

Protected by copyright. Copying for private or commercial purposes, in part or in whole, is not permitted unless authorised by AUDI AG. AUDI AG does not guarantee or accept any liability with respect to the correctness of information in this document. Copyright by AUDI AG.



System components

Pneumatic diagram

Air supply unit

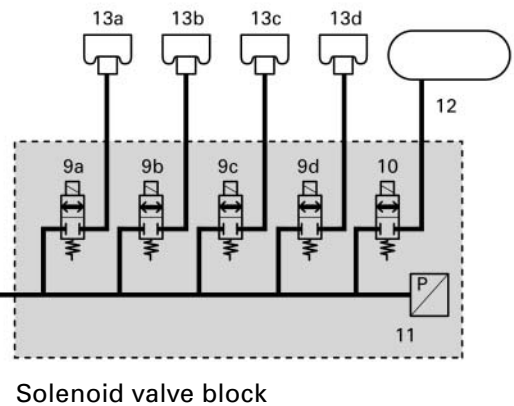
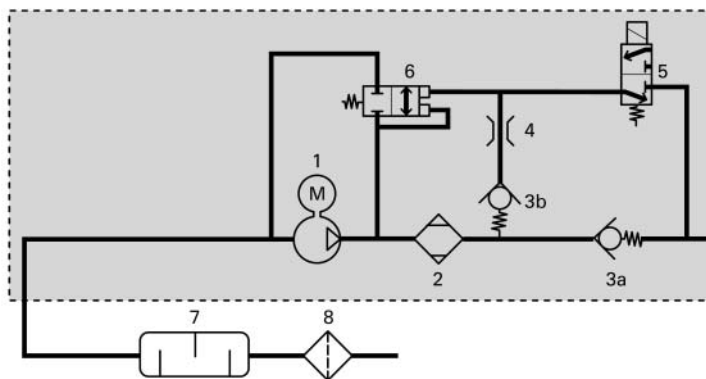

292_020

1	Compressor V66	9c	Valve for strut RL N150
2	Air drier	9d	Valve for strut RR N151
3a, 3b	Non-return valves	10	Valve for accumulator N311
4	Exhaust throttle	11	Pressure sender G291
5	Electrical exhaust solenoid valve N111	12	Accumulator
6	Pneumatic exhaust solenoid valve	13a	Pneumatic spring FL
7	Additional silencer	13b	Pneumatic spring FR
8	Air filter	13c	Pneumatic spring RL
9a	Valve for strut FL N148	13d	Pneumatic spring RR
9b	Valve for strut FR N149		

Protected by copyright. Copying for private or commercial purposes, in part or in whole, is not permitted unless authorised by AUDI AG. AUDI AG does not guarantee or accept any liability with respect to the correctness of information in this document. Copyright by AUDI AG.



Pressure build-up

The valves 9a, 9b and 9c, 9d are electrically actuated in pairs (front axle and rear axle). The compressor takes in the air through the air filter 8 and the additional silencer 7. The compressed air flows via the air drier 2, the non-return valve 3a and the valves 9 to the pneumatic springs.

When the pneumatic springs are filled by the accumulator, the valve 10 and the valves 9 for the appropriate axle open.

The accumulator 12 is filled by the compressor 1 forcing air through the open valve 10. If the vehicle is on a sideways incline, valves 9a - 9d are also actuated individually.

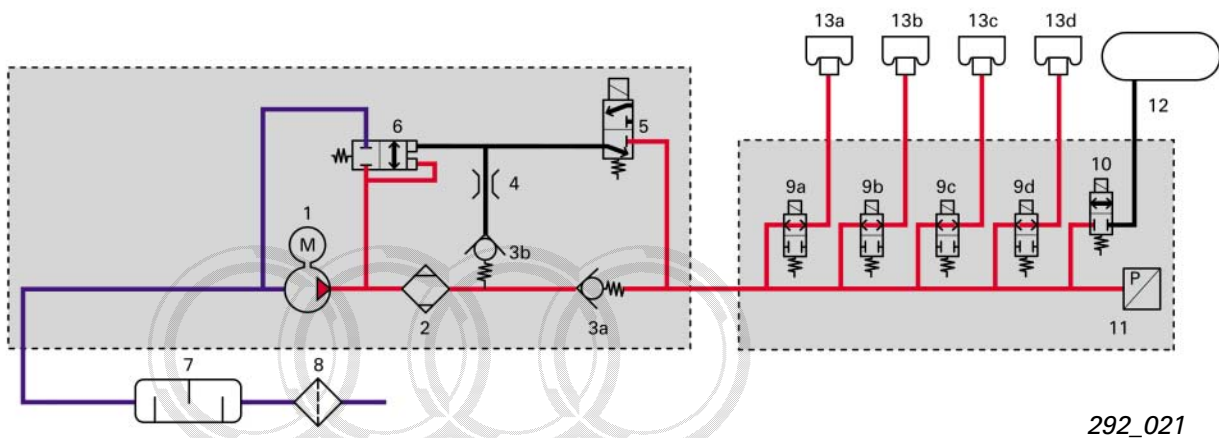
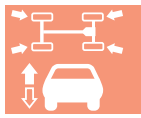

Pressure reduction

The appropriate valves 9a, 9b and 9c, 9d and the electrical exhaust solenoid valve 5 are opened. The air can flow through the exhaust solenoid 5 to open the pneumatic, pilot-operated exhaust solenoid 6.

The air leaves the system via exhaust solenoid 6, additional silencer 7 and air filter 8. When air flows through the air drier 2, the desiccant is regenerated.

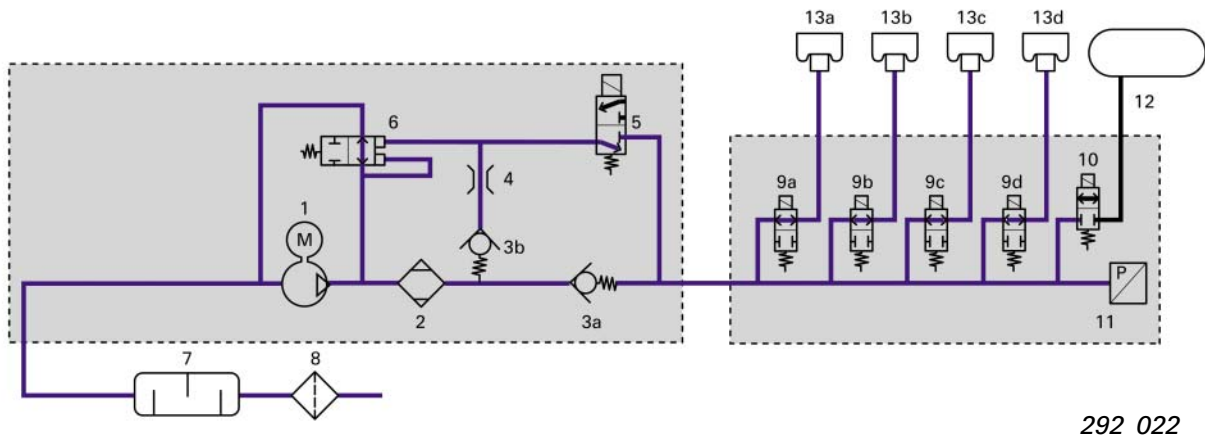

System components

Senders (sensors)

Compressor temperature sender G290

Construction:

An NTC resistor is housed in a small glass case.

Function:

The sender records the temperature of the cylinder head compressor. Its resistance decreases sharply as the temperature rises (NTC: **n**egative **t**emperature **c**oefficient). This change in resistance is analysed by the control unit. The current temperature calculated in each case determines the maximum compressor running time. The sender cannot be replaced separately during servicing.



Temperature sensor

292_017

Pressure sender G291

Construction:

The sender is cast in the solenoid valve block and is inaccessible from the outside.

Function:

The pressure sender measures the pressure of the front and rear axle struts or the accumulator (depending on how the solenoid valves are actuated, see pneumatic diagram). The G291 employs a capacitive measuring technique:

The pressure (p) to be measured causes a ceramic diaphragm to deflect. This deflection changes the distance between an electrode (1) attached to the diaphragm and a stationary counter-electrode (2) on the sender housing.

The electrodes together form a capacitor. The smaller the distance between the electrodes, the greater the capacitance of the capacitor. This capacitance is measured by the integrated electronics and converted to a linear output signal.

Protected by copyright. Copying for private or commercial purposes, in part or in whole, is not permitted unless authorised by AUDI AG. AUDI AG does not guarantee or accept any liability with respect to the correctness of information in this document. Copyright by AUDI AG.

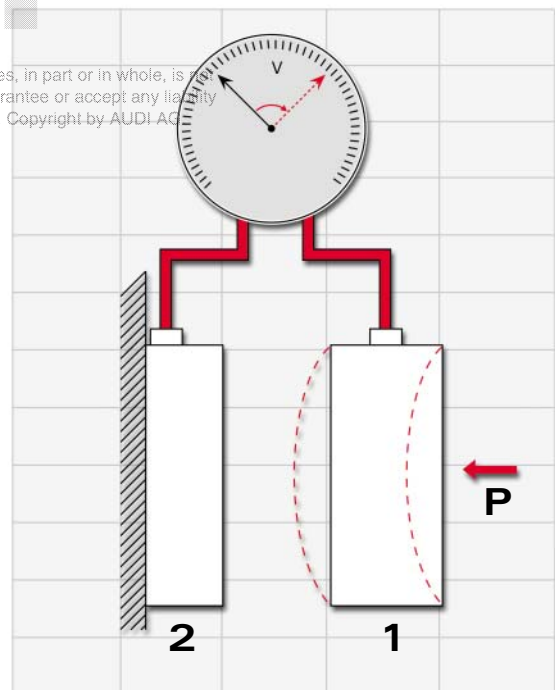

292_024

Acceleration sender

In order to achieve optimum damping for every driving condition, knowledge of the body movement (sprung mass) and axle components (unsprung mass) characteristic over time is required. The acceleration of the body is measured by three senders.

Two of these are situated on the front axle MacPherson strut towers, the third in the rear right wheel housing. The acceleration of the axle components (unsprung masses) is determined by evaluating the signals from the vehicle level senders.

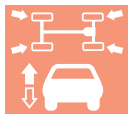

Body acceleration senders G341, G342, G343

The senders are bolted to the body with brackets. The senders and brackets are crimped together.



The crimp must not be tampered with! During service work, the sender must always be replaced together with the bracket. When installed correctly, the arrow on the sender housing must point upwards!

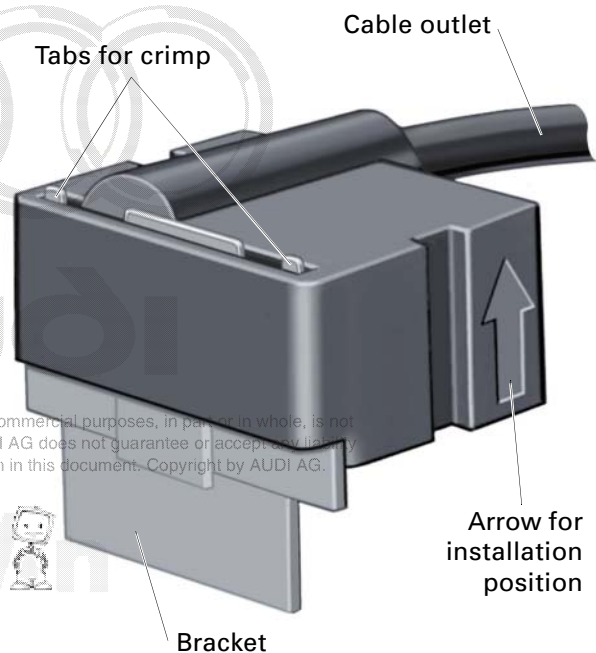

292_025

Construction:

The sender element consists of several layers of silicon and glass. The middle silicon layer takes the form of a spring-loaded reed (seismic mass). The sensitivity of the sender is predominantly determined by the spring rate and the mass of the reed.

Function:

The metal-coated seismic mass acts as a moving electrode which, together with the upper and lower counter-electrodes, forms capacitors. The capacitance of these is dependent upon the electrode surfaces and their distance from one another.

System components

Rest condition:

The seismic mass is situated exactly in the middle between the counter-electrodes. The two capacitors C1 and C2 have the same capacitance.

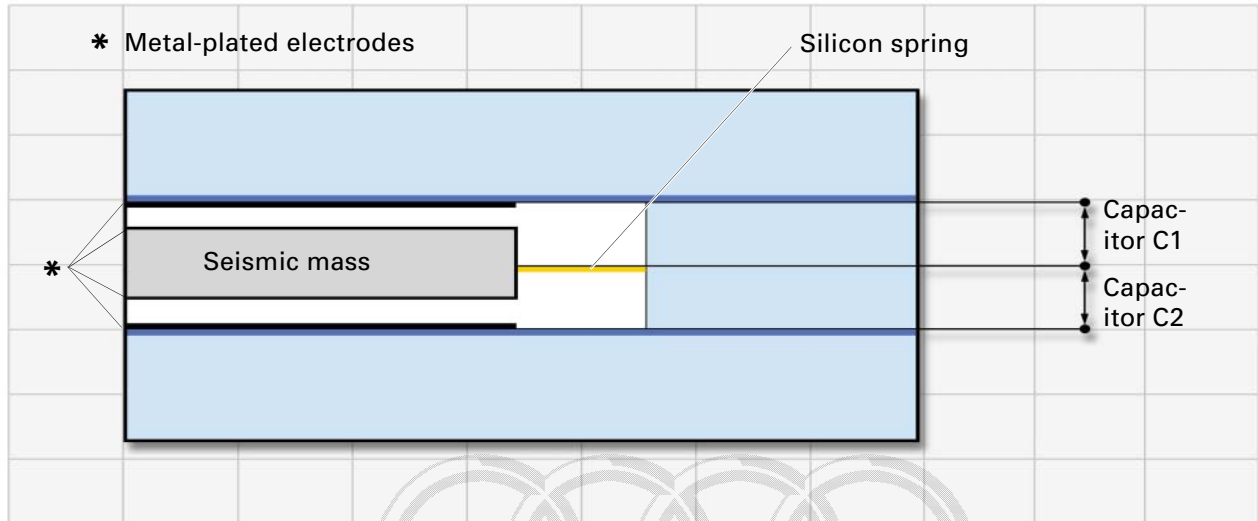

292_026

Accelerated condition:

Mass inertia causes the seismic mass to be deflected from its central position. The distance between the electrodes changes. As the distance is reduced, the capacitance increases.

The supply voltage is provided by the pneumatic spring system's control unit. The current voltage values of body acceleration can be read out by means of measured data blocks.

In the example below, the capacitance of capacitor C2 is greater than in rest condition, whereas that of capacitor C1 decreases.

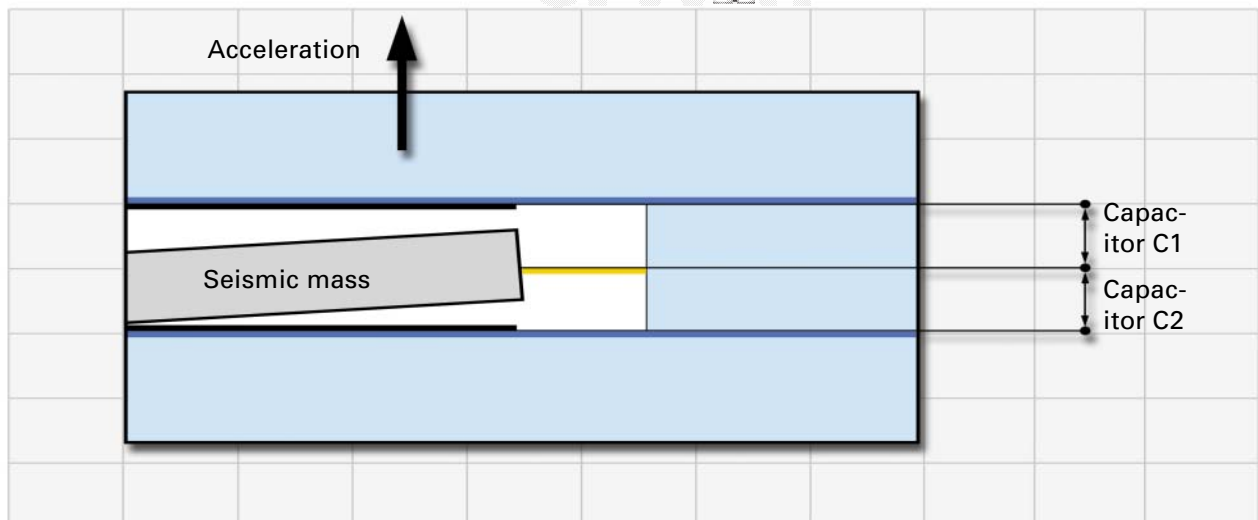

292_027

Vehicle level senders G76, G77, G78, G289

Construction:

The sender construction and the PIN designation are the same as those of the allroad quattro (description in SSP no. 243). The four senders are interchangeable, but the brackets and coupling rods must be fitted to the correct side and axle.

Function:

The senders record the distance between the links and the body, and thus the level of the vehicle. The sensing function is now effected with 800 Hz (200 Hz in the allroad). This scanning frequency is sufficient to determine the acceleration of the unsprung masses.

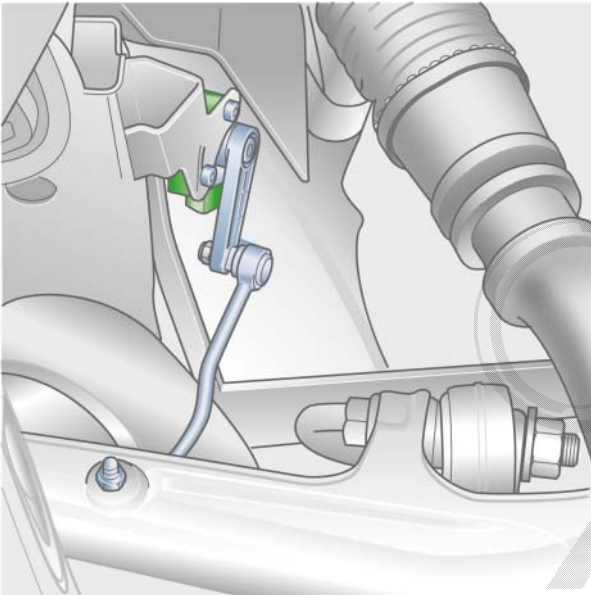
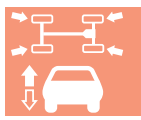

292_028

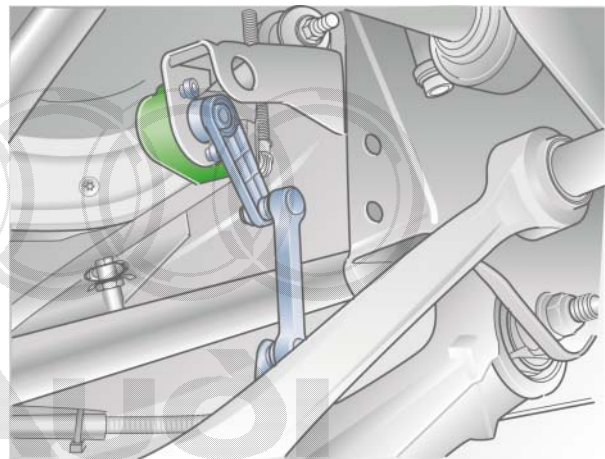

292_034

Protected by copyright. Copying for private or commercial purposes, in part or in whole, is not permitted unless authorised by AUDI AG. AUDI AG does not guarantee or accept any liability with respect to the correctness of information in this document. Copyright by AUDI AG.



Installing the geometrically identical sender of the allroad quattro in the A8 leads to system failure and is not permitted.

System functions

General control concept

Changes in level are effected by axle, with correction of differences in level between the left and right-hand sides (e.g. caused by one-sided loading of the vehicle)

At vehicle speeds of 22 mph (35 km/h) or less, the accumulator is the preferred energy source. A prerequisite for this is a pressure difference of at least 3 bar between the accumulator and the pneumatic springs.



Level change procedure:

Lifting:

First the rear axle is lifted, then the front axle

Lowering:

First the front axle is lowered, then the rear axle

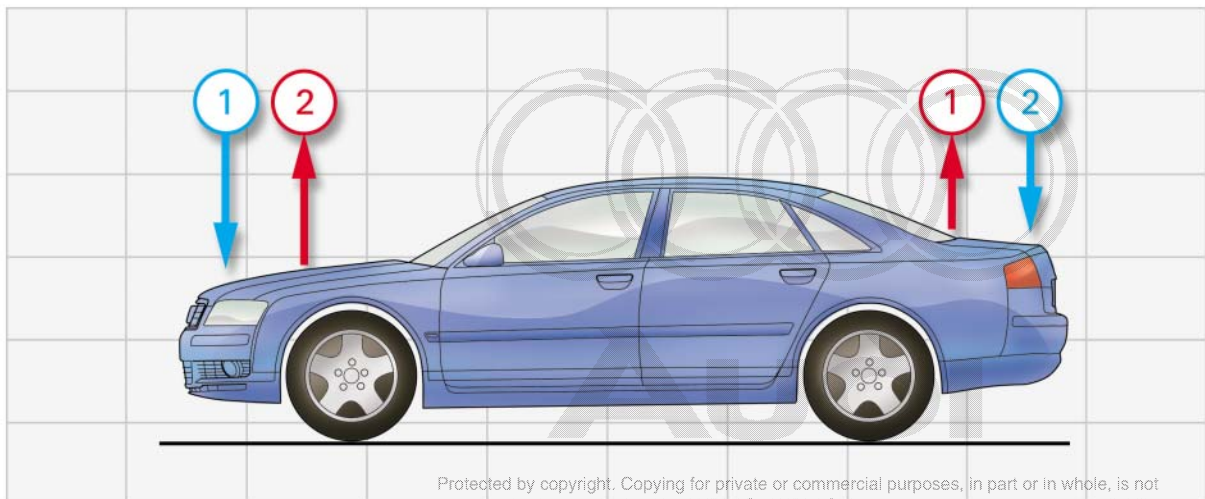

Protected by copyright. Copying for private or commercial purposes, in part or in whole, is not permitted unless authorised by AUDI AG. AUDI AG does not guarantee or accept any liability with respect to the correctness of information in this document. Copyright by AUDI AG.



292_029

This sequence ensures that oncoming traffic will not be dazzled during levelling operations, even in the event of failure of the headlight range control. Headlight range control is only employed in vehicles with Xenon headlights.

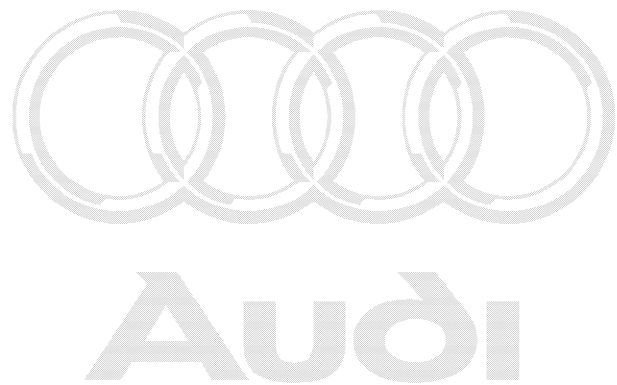

Protected by copyright. Copying for private or commercial purposes, in part or in whole, is not permitted unless authorised by AUDI AG. AUDI AG does not guarantee or accept any liability with respect to the correctness of information in this document. Copyright by AUDI AG.



System functions

Control concept for standard running gear

"automatic" mode (basic level)

The suspension is oriented towards a more comfortable ride.

Automatic motorway lowering of 25 mm takes place after 30 seconds at speeds of 75 mph (120 km/h) or more.

The vehicle is automatically lifted back up to basic level once the speed drops below 44 mph (70 km/h) for 120 seconds or if the speed drops below 22 mph (35 km/h).



"dynamic" mode (-20 mm)

Here, a taut damping map is applied to the vehicle's entire speed range.

When the vehicle speed exceeds 75 mph (120 km/h) for 30 seconds, the vehicle is automatically lowered by a further 5 mm (motorway).

The vehicle is automatically lifted back to the sporty level once the speed drops below 44 mph (70 km/h) for 120 seconds or if the speed drops below 22 mph (35 km/h).

"comfort" mode (basic level)

The suspension is even more comfort-oriented than in "automatic" mode, particularly at lower speeds.

There is no automatic motorway lowering.

"lift" mode (+25 mm)

This mode can only be selected at speeds of less than 50 mph (80 km/h).

The controller automatically leaves this mode at speeds of 63 mph (100 km/h). It then reverts to the mode which was previously selected ("automatic", "dynamic" or "comfort").

Even if the speed again drops below 50 mph (80 km/h), the "lift" mode is not automatically adopted.

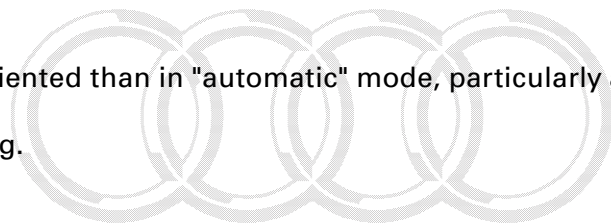

Audi

erWin 

System functions

Control concept for sporty running gear

- Differences from the standard running gear:
- Different, sporty suspension and damping
 - Same levels but different damping maps for "dynamic", "automatic" and "comfort" modes at speeds of less than 75 mph (120 km/h)
 - Basic vehicle level 20 mm lower than with standard running gear

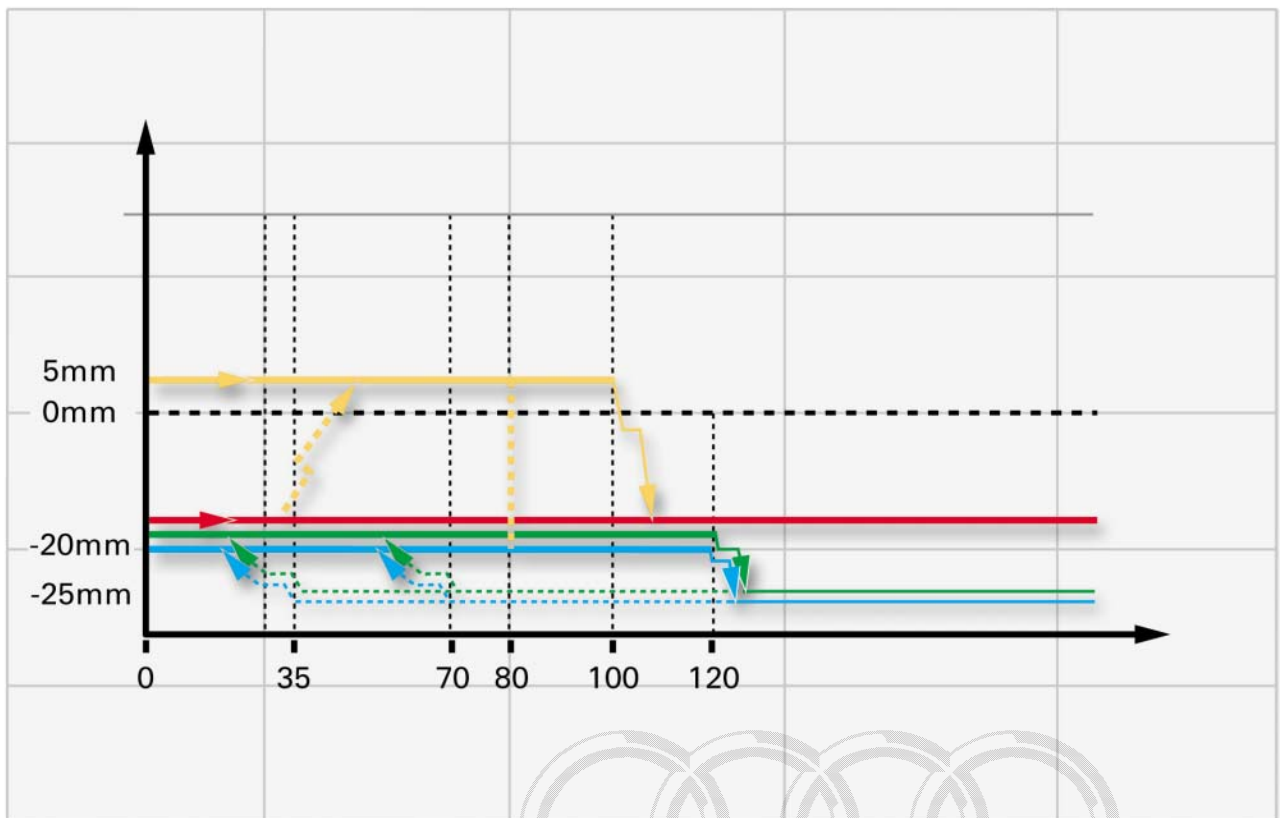

292_052

- "lift"
- "automatic"
- "comfort"
- "dynamic"
- Basic level of standard running gear

Acceptance level for selecting "lift" mode 50 mph (80 km/h)

System automatically leaves "lift" mode at $v > 63$ mph (100 km/h), vehicle is not lifted back up automatically

Automatic lift to revert to sporty level (dependent on speed/time)

Automatic motorway lowering after > 30 s at $v > 75$ mph (120 km/h)

Control concept for special operating conditions

Cornering

Suspension adaptation is interrupted during cornering manoeuvres and continued afterwards.

The system recognises that cornering is taking place by means of the signals from the steering angle and lateral acceleration senders.

The damping forces are adapted to suit the current driving situation.

This effectively eliminates undesirable body movements (e.g. rolling) caused by the driving dynamics.

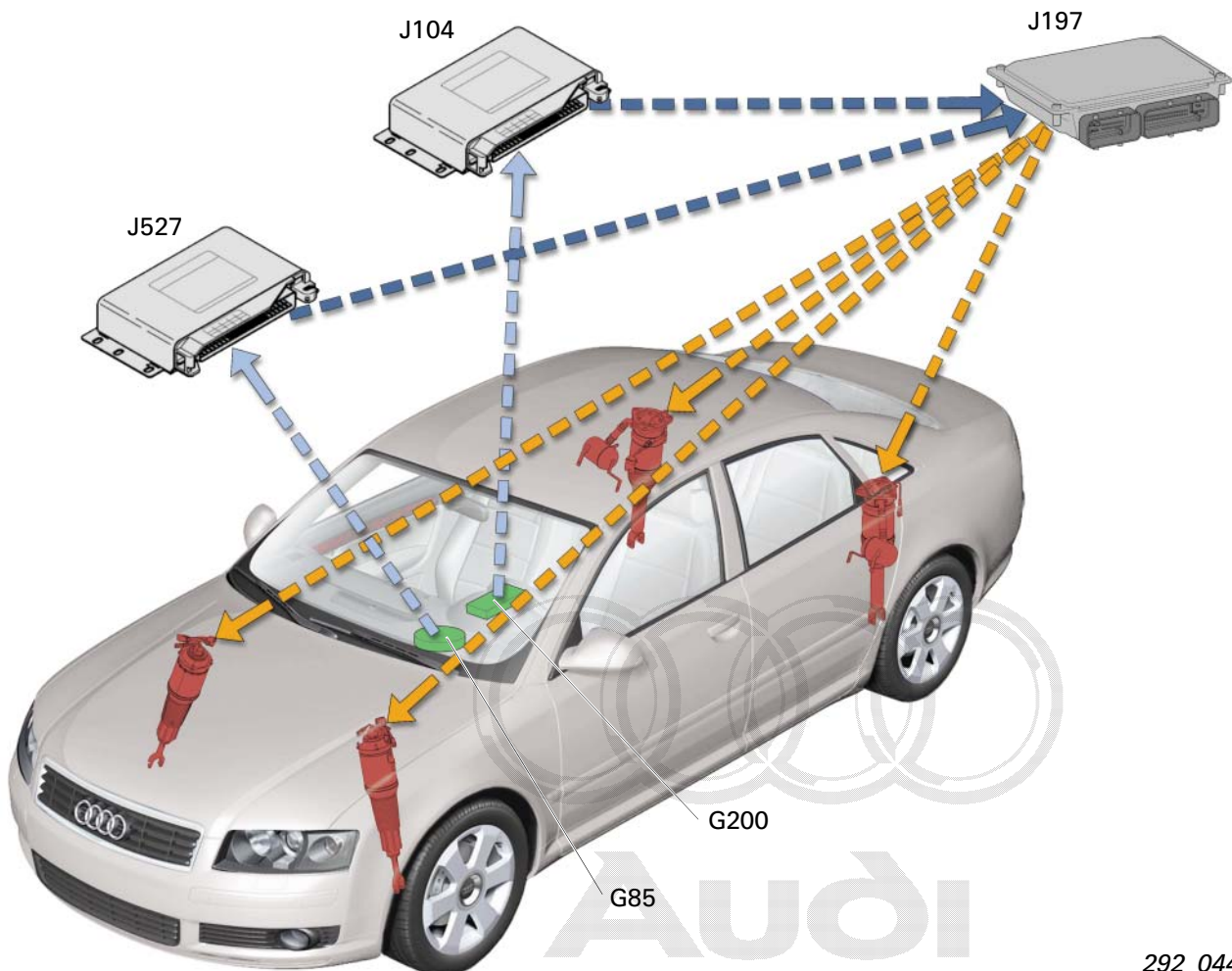

292_044

Protected by copyright. Copying for private or commercial purposes, in part or in whole, is not permitted unless authorised by AUDI AG. AUDI AG does not guarantee or accept any liability with regard to the correctness of information in this document. Copyright by AUDI AG.

- J107 Adaptive air suspension control unit
- J104 ESP control unit
- J527 Control unit for steering column electronics
- G200 Lateral acceleration sender
- G85 Steering angle sender



System functions

Braking manoeuvres

Damping control is employed, particularly during ABS/ESP braking manoeuvres. Damping is regulated as a function of the current braking pressure.

This keeps nose diving, squatting and rolling of the vehicle body to a minimum.

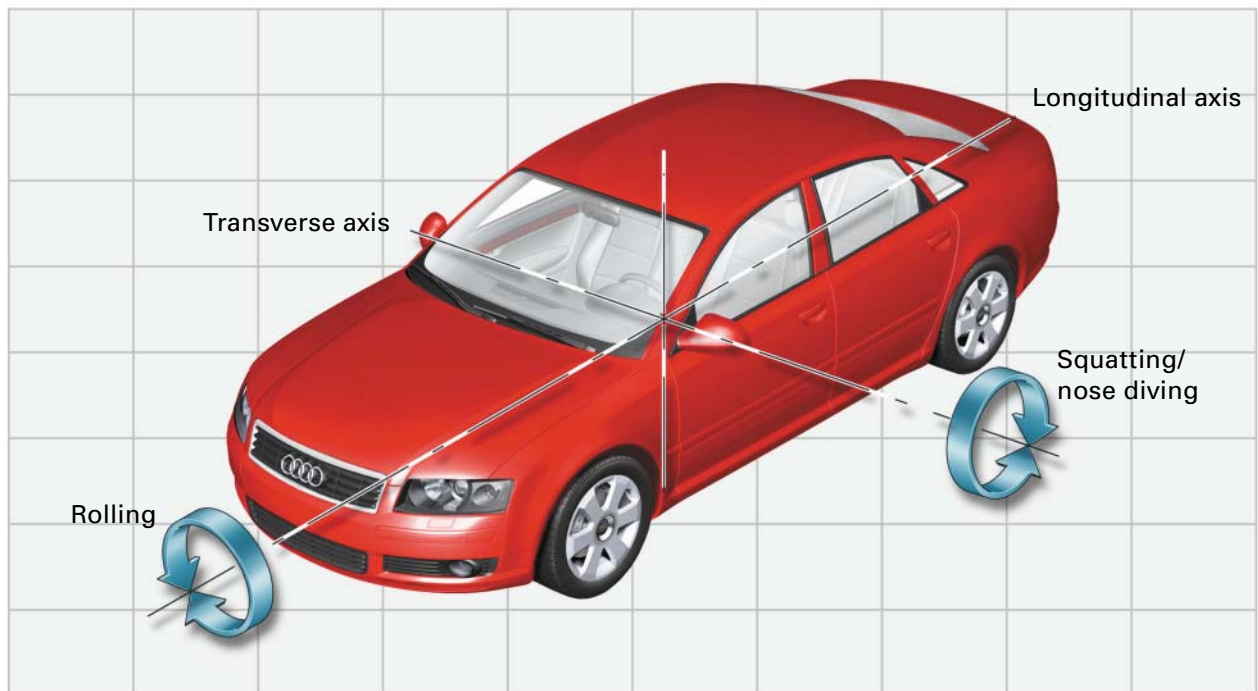

292_033

Starting manoeuvres

During starting manoeuvres, the mass inertia of the body leads above all to squatting. Appropriate damping forces that are adapted to the current situation restrict these movements to a minimum.

Protected by copyright. Copying for private or commercial purposes, in part or in whole, is not permitted unless authorised by AUDI AG. AUDI AG does not guarantee or accept any liability with respect to the correctness of information in this document. Copyright by AUDI AG.

erWin 

Pre-travel and after-run mode

Any difference from the specified height before driving commences or before ignition on is corrected.

When the door, boot lid or terminal 15 is actuated, the system is woken from sleep mode and goes into pre-travel mode (see section on Interfaces).

Any difference in height caused, for example, by climbing out of or unloading the vehicle after switching off the ignition, is corrected in after-run mode.



Sleep mode

After 60 seconds in after-run mode without receiving an input signal, the system goes into the energy-saving sleep mode. The system leaves sleep mode briefly after 2, 5 and 10 hours to check the height level again.

Any difference in height from the specified value (e.g. due to the cooling of the air in the pneumatic springs) is corrected by the accumulator.

Lifting-platform mode

The system recognises lifting-platform mode by evaluating the signals from the vehicle level sender and by the length of time that the stationary vehicle has been shutdown. No fault is stored in the fault memory. This mode is not displayed by the indicator lamp.

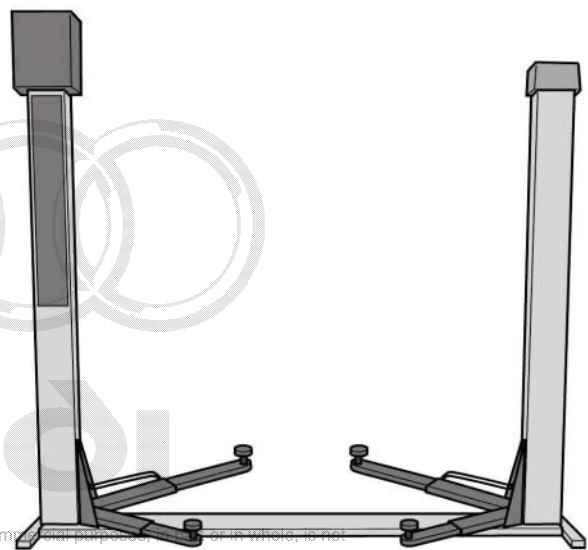

Protected by copyright. Copying for private or commercial purposes, in whole or in part, is not permitted unless authorised by AUDI AG. AUDI AG does not guarantee or accept any liability with respect to the correctness of information in this document. Copyright by AUDI AG.

292_034



System functions

Using a jack (service mode)

There is no automatic recognition.

Adaptive air suspension must be deactivated if a jack is to be used. This is done by actuating the MMI control knob in the CAR -> SETUP menu.

This mode is deactivated either by resetting in MMI or by driving at a speed of >9 mph (15 km/h).

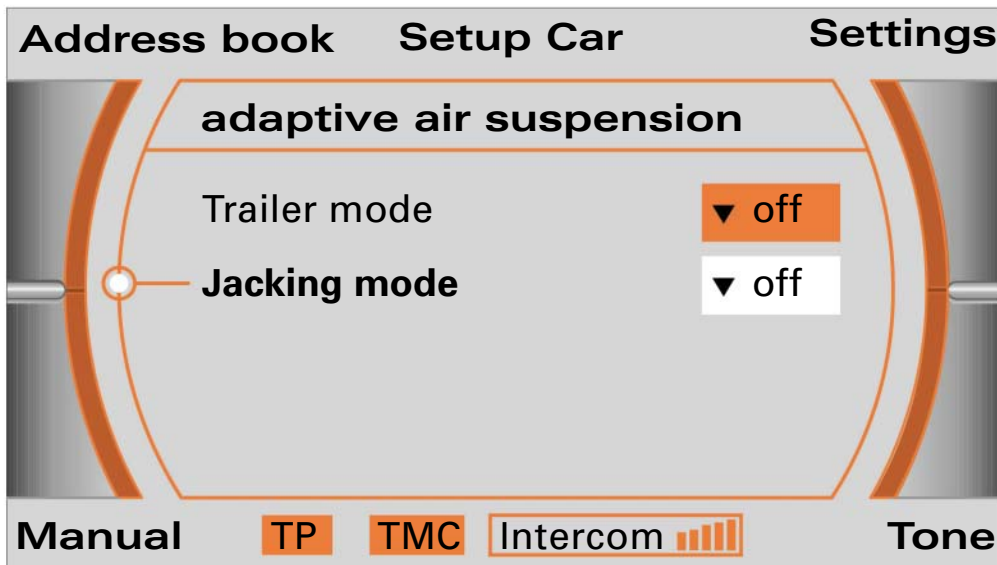

292_036

Trailer mode

Trailer mode is recognised automatically when the trailer is electrically connected to the towing vehicle.

The system status (trailer mode on or off) can be requested by means of the SETUP button and activated if necessary using the MMI control knob.

In the standard running gear, "dynamic" mode cannot be selected in trailer mode.

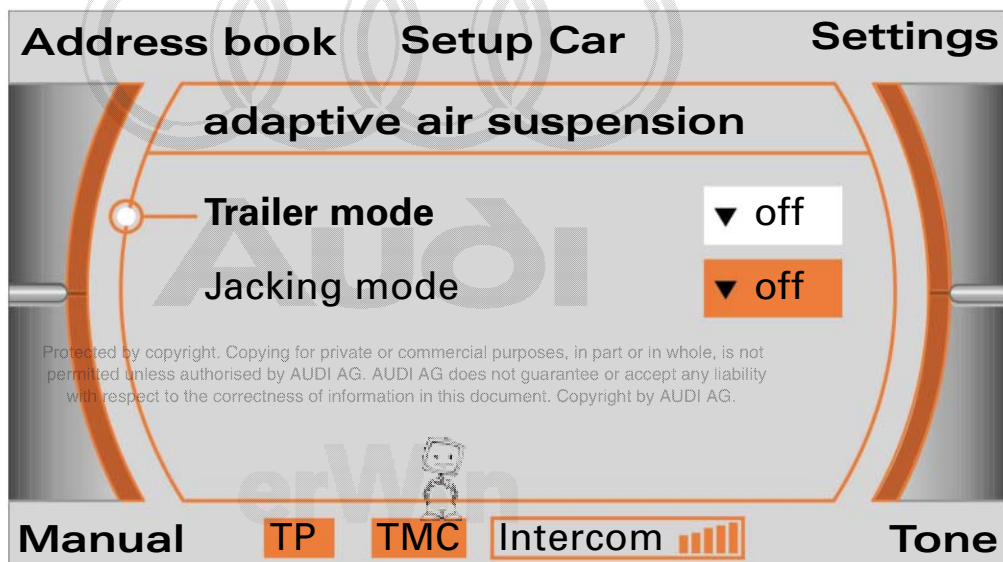

Protected by copyright. Copying for private or commercial purposes, in part or in whole, is not permitted unless authorised by AUDI AG. AUDI AG does not guarantee or accept any liability with respect to the correctness of information in this document. Copyright by AUDI AG.

292_035

Extreme low level

Extreme low level (65 mm or more below normal level) is shown by the low level indicator lamp and the warning lamp flashing. Extreme low level can occur after the vehicle has been at a standstill for a very long period.



292_045

Extreme high level

Extreme high level (50 mm or more above normal level) is shown by the warning lamp flashing. Extreme high level may occur briefly when heavy objects are unloaded.



292_046

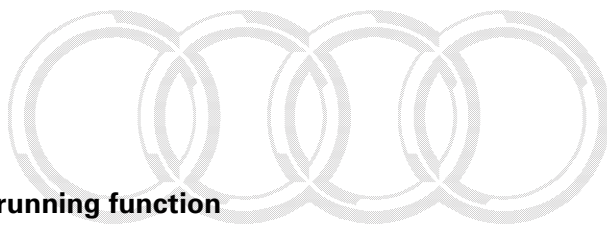

Emergency running function

If a failure of system components or signals is detected, the full functional reliability of the system is generally no longer guaranteed. Therefore, depending on the severity of the fault, an emergency running program is started. Faults are stored in the fault memory. The warning lamp in the dash panel insert comes on.

The premise for emergency running mode is the maintenance of driving stability. Excessively soft suspension is prevented. In the event of complete failure of the system control, the damper actuation is de-energized and the system is set to hard suspension. (See "Shock absorber" description in the "System components" section)



Interfaces

System overview of components with bus link (CAN, MOST)

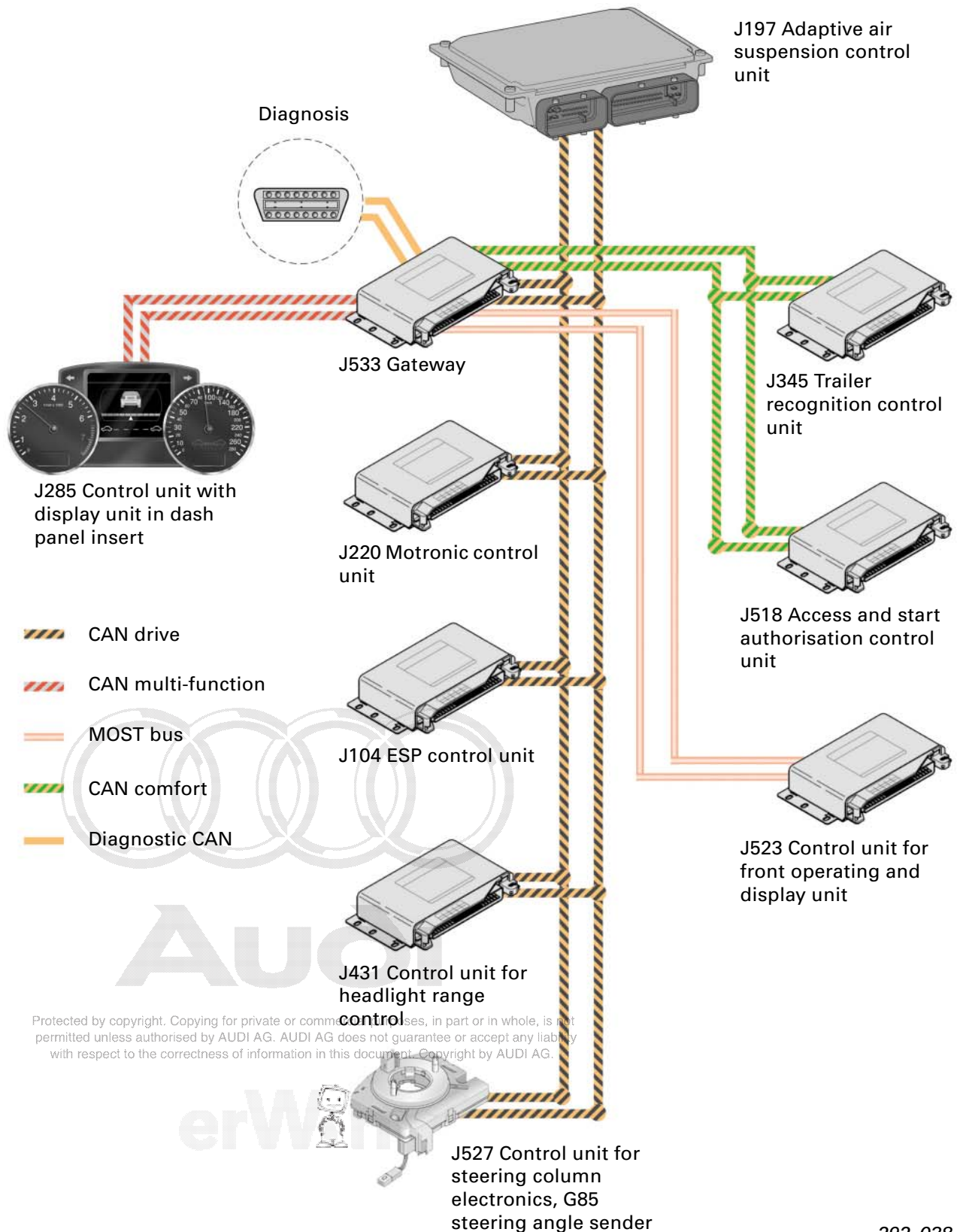

292_038

System overview of components without bus link

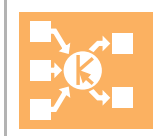
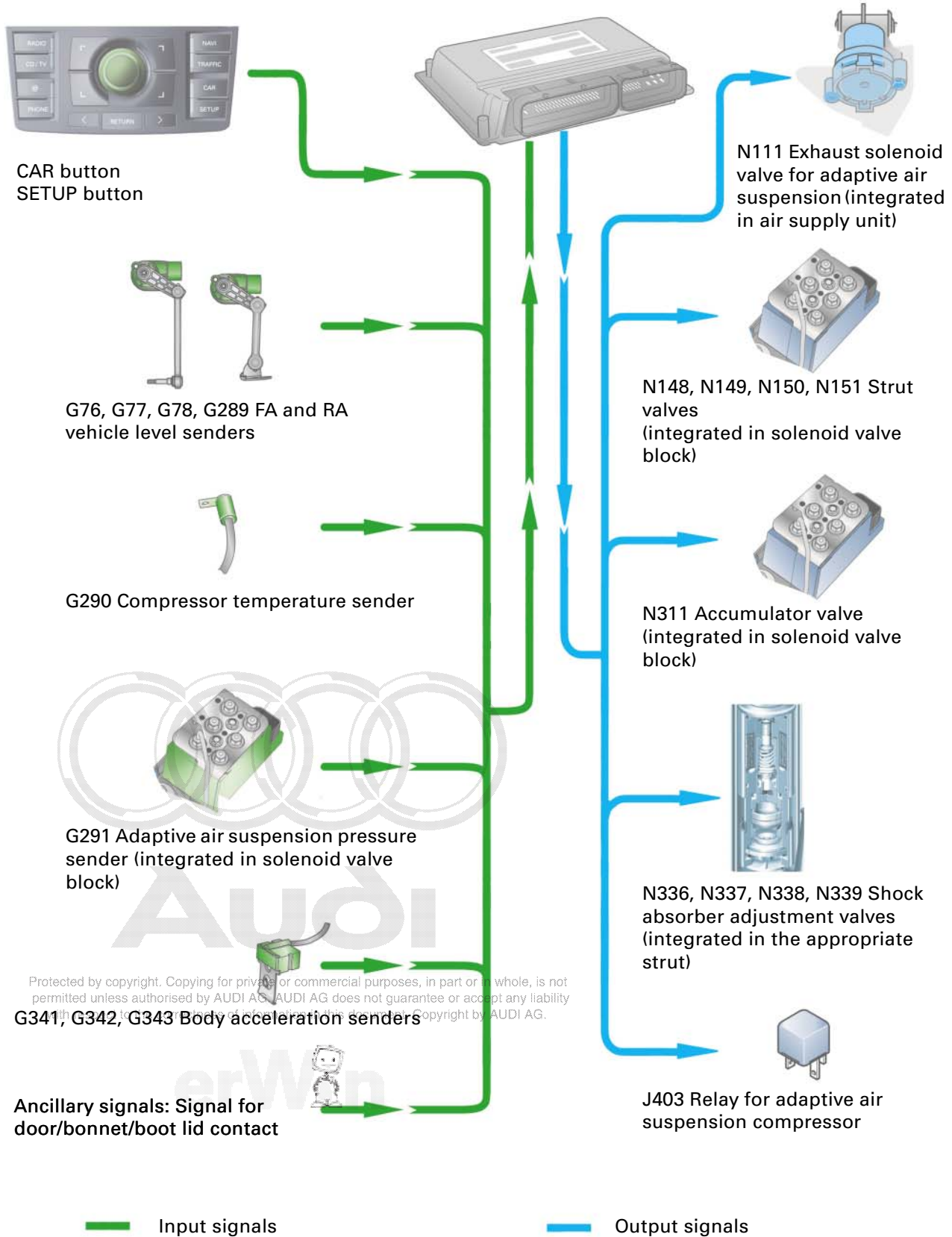

Protected by copyright. Copying for private or commercial purposes, in part or in whole, is not permitted unless authorised by AUDI AG. AUDI AG does not guarantee or accept any liability for the accuracy or completeness of information published on this document. Copyright by AUDI AG.

Interfaces

CAN information exchange

J197 Adaptive air suspension control unit

- System status (all)
- Actuate warning lamp (5)
- Actuate low level indicator (5)
- Advance warning of level adjustment (4)
- Advance warning of compressor start-up (4)
- Lifting/lowering (4)
- Height of FR, FL, RR, RL (4)

J533 Gateway

- Reversing light On/Off
- Current status of mileage, time, trailer recognition signals

J285 Control unit with display unit in dash panel insert (5)

- Mileage
- Date and time

J345 Trailer recognition control unit (6)

- Trailer recognition

J518 Access and start authorisation control unit (7)

- Terminal X (for starting)

J523 Control unit for front operating and display unit (8)

- Mode selection and display
- Activate/deactivate trailer mode

Protected by copyright. Copying for private or commercial purposes, in part or in whole, is not permitted unless authorised by AUDI AG. AUDI AG does not guarantee or accept any liability with respect to the correctness of information in this document. Copyright © 2014 by AUDI AG.

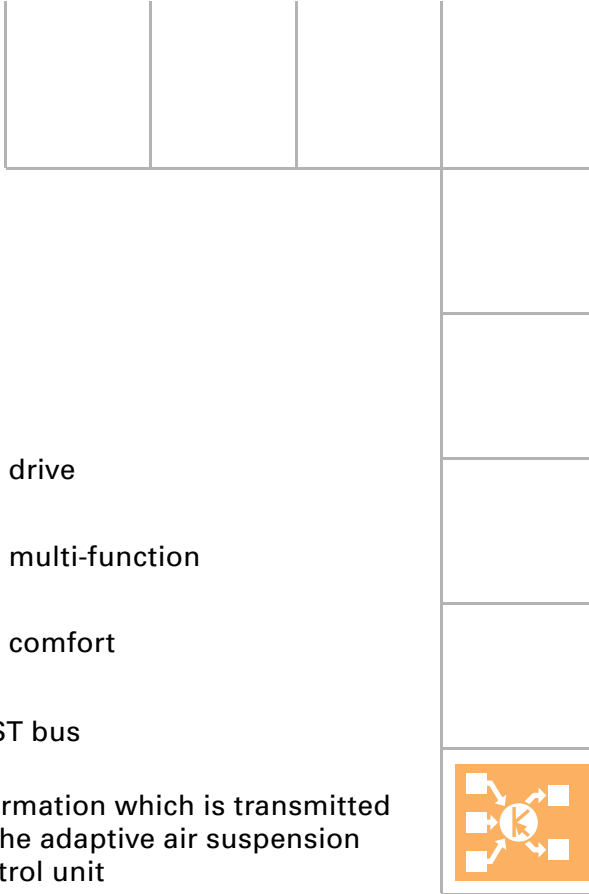

J220 Motronic control unit (1)

- Engine speed
- Driver's desired torque
- Current position of brake light switch
- Current position of brake test switch







J104 ESP control unit (2)

- ABS braking activated
- ESP override activated
- Current vehicle speed
- Lateral acceleration
- Braking pressure

J527 Control unit for steering column electronics
G85 Steering angle sender

- Steering wheel angle
- System status

J431 Control unit for headlight range control (4)
 (receiver only)

-  CAN drive
-  CAN multi-function
-  CAN comfort
-  MOST bus
-  Information which is transmitted by the adaptive air suspension control unit
-  Information which is received and evaluated by the adaptive air suspension control unit

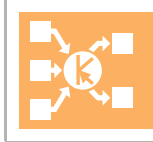

Protected by copyright. Copying for private or commercial purposes, in part or in whole, is not permitted unless authorised by AUDI AG. AUDI AG does not guarantee or accept any liability with respect to the correctness of information in this document. Copyright by AUDI AG.
 292_038



The numbers in brackets after the message content designate the control unit that processes the information in question: e.g.: Activate warning lamp is processed by control unit no. 5, J285.

Interfaces

Function diagram

- G76 Vehicle level sender, rear left
- G77 Vehicle level sender, rear right
- G78 Vehicle level sender, front left
- G289 Vehicle level sender, front right
- G290 Temperature sender for adaptive air suspension compressor
- G291 Adaptive air suspension pressure sender
- J393 Central control unit for comfort system (for door signal)
- G341 Body acceleration sender, front left
- G342 Body acceleration sender, front right
- G343 Body acceleration sender, rear
- J197 Adaptive air suspension control unit
- J403 Relay for adaptive air suspension compressor
- N111 Adaptive air suspension exhaust solenoid valve
- N148 Strut valve, front left
- N149 Strut valve, front right
- N150 Strut valve, rear left
- N151 Strut valve, rear right
- N311 Valve for adaptive air suspension accumulator
- N336 Strut valve, front left
- N337 Valve for shock absorber adjustment, front right
- N338 Valve for shock absorber adjustment, rear left
- N339 Valve for shock absorber adjustment, rear right
- V66 Motor for adaptive air suspension compressor

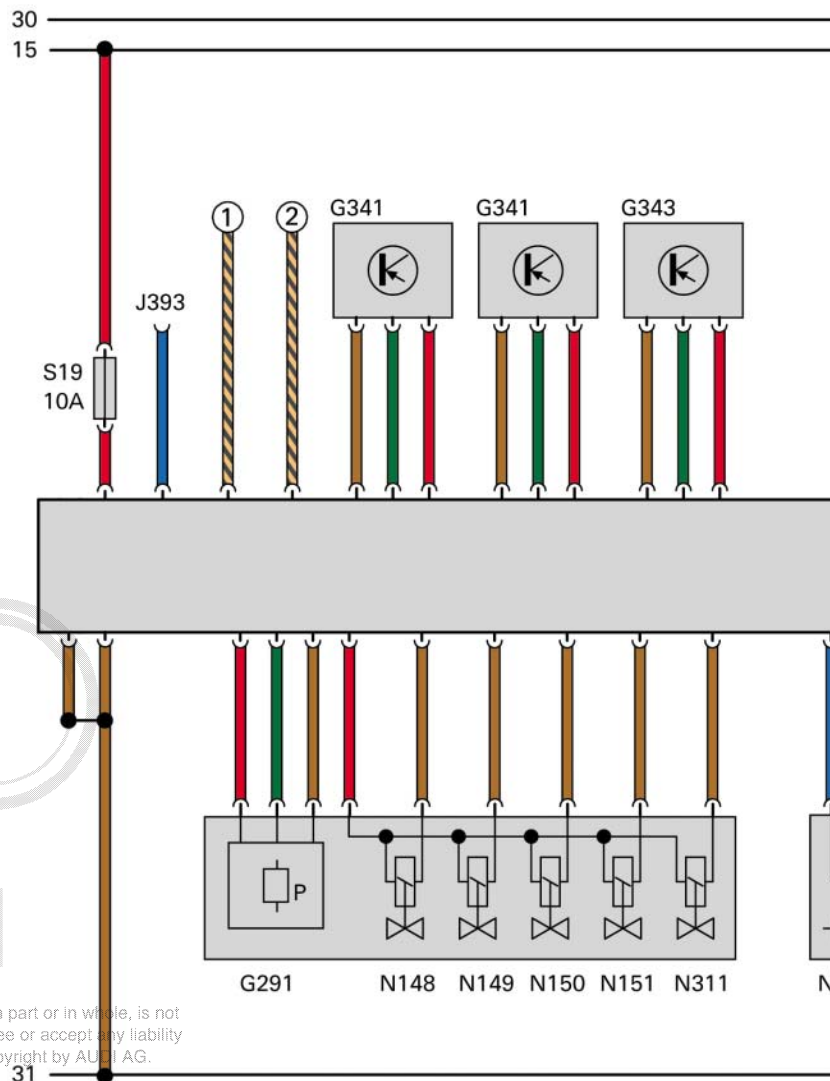

Protected by copyright. Copying for private or commercial purposes, in part or in whole, is not permitted without the prior written consent of the copyright holder. Audi AG does not guarantee or accept any liability with respect to the correctness of information in this document. Copyright by AUDI AG.

Colour coding

- = input signal
- = output signal
- = positive supply
- = earth
- = CAN bus

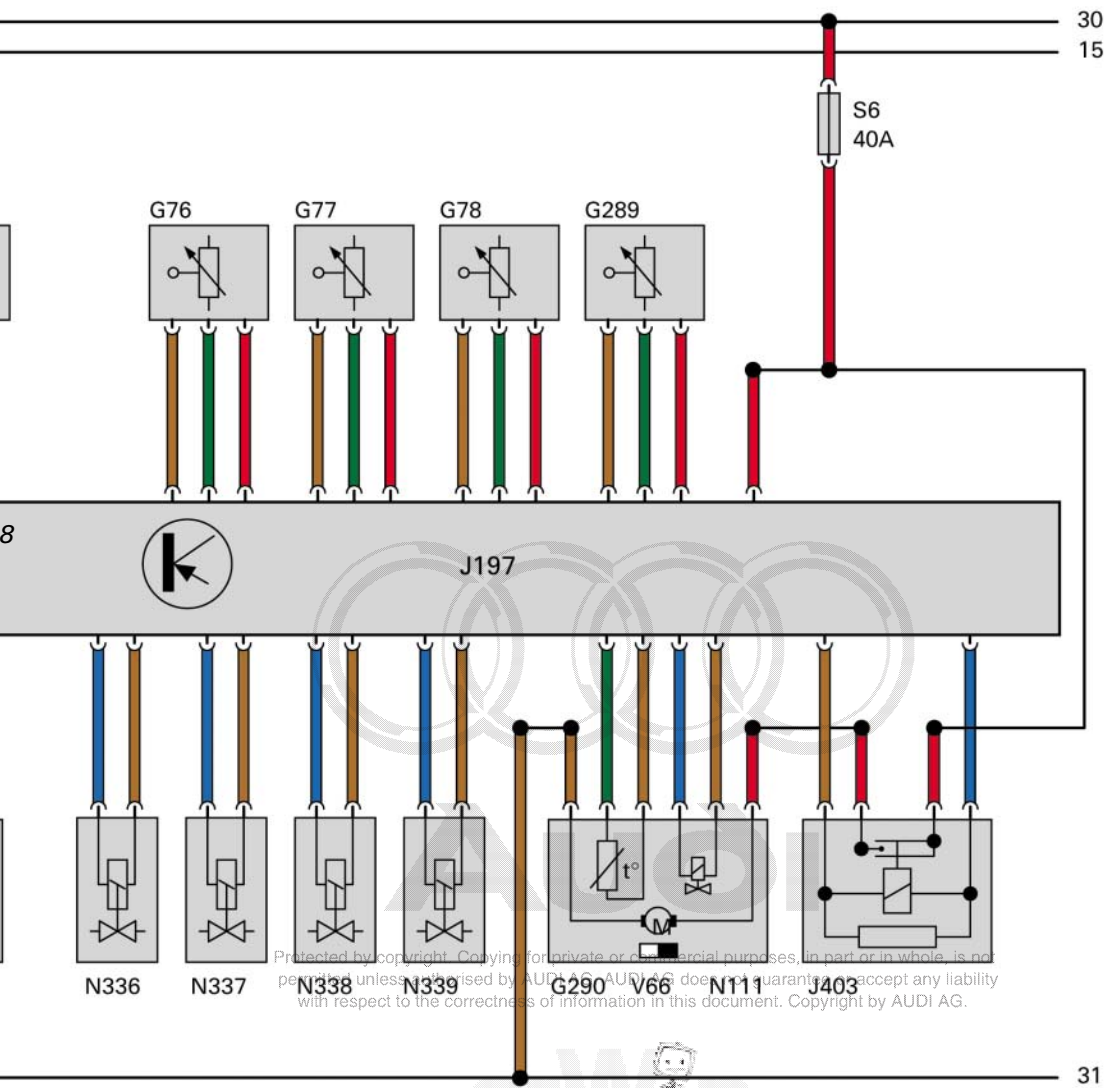

Protected by copyright. Copying for private or commercial purposes, in part or in whole, is not permitted unless authorised by AUDI AG. AUDI AG does not warrant, accept any liability with respect to the correctness of information in this document. Copyright by AUDI AG.

292_051

Ancillary signals

- ① CAN High
- ② CAN Low

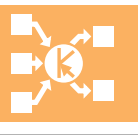

Interfaces

Other interfaces

The wake-up signal

to wake the adaptive air suspension control unit from sleep mode is transmitted by the comfort system central control unit J393. It uses a pulse-width-modulated signal. The duration of the signal pulse varies depending on whether the doors and/or boot lid are opened or closed.

J393 transmits a signal even if terminal 15 is detected but the doors and/or boot lid are not opened or closed.

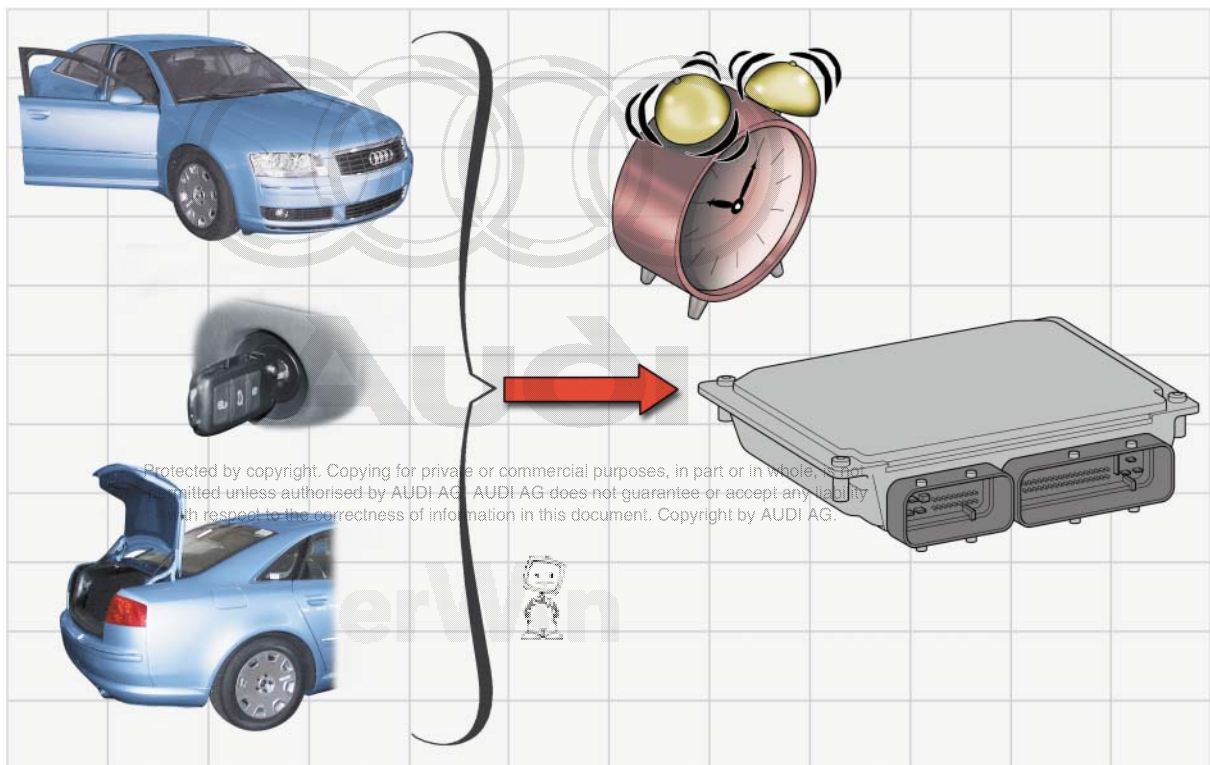

292_047

Service

Control unit code

The code for both the standard and the sporty running gear is 15500.

System initialisation

The system initialisation process includes calibration of the vehicle level senders. This is required whenever a sender or the control unit is replaced. System initialisation is performed using diagnostic tester VAS 5051 (address word: 34 – adaptive air suspension).

The height of each wheel is measured from the centre of the wheel to the lower edge of the wheel housing. The measured values are transmitted one after the other to the control unit by means of function 10, "Adaptation". The specified dimensions are stored in the control unit. The correction factors can be determined by comparing the specified values with the measured values.

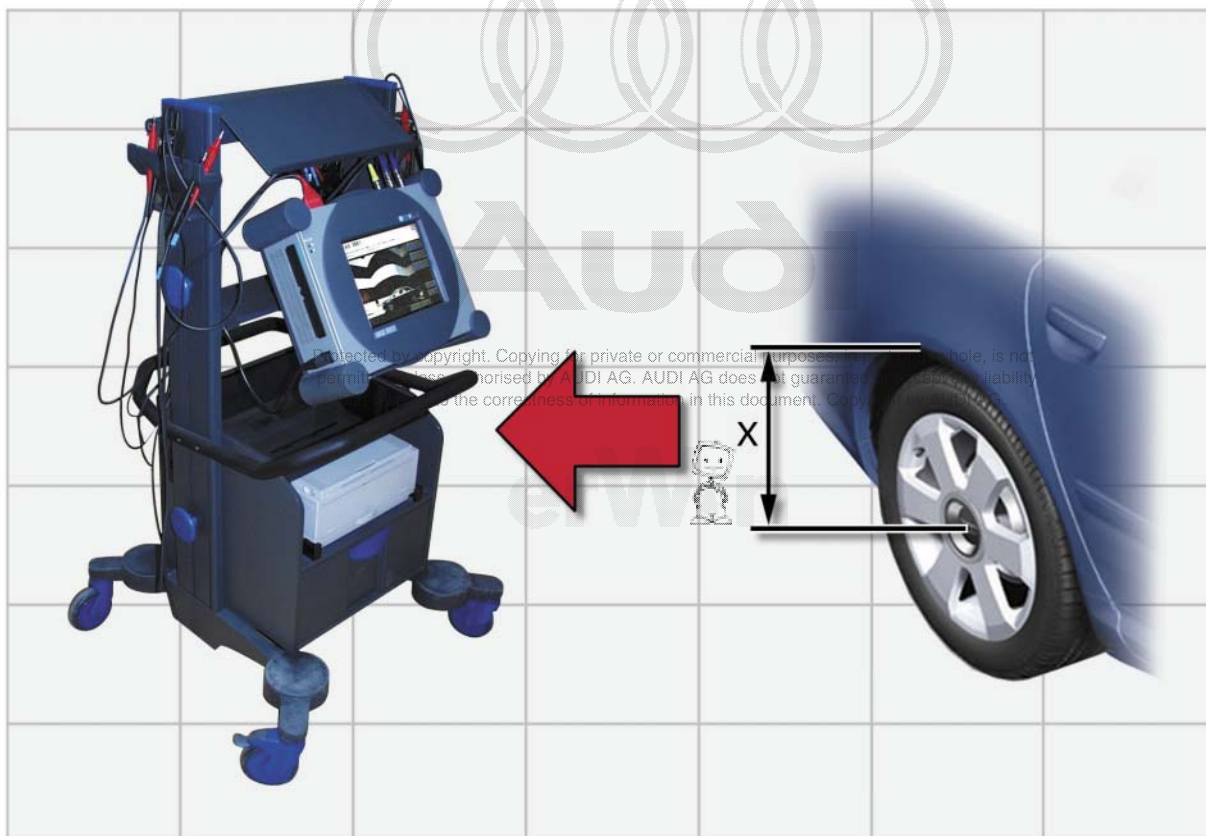

292_041

Final control diagnosis

Final control diagnosis checks the function of the compressor, the solenoid valves and the struts/shock absorbers.

Diagnosis is executed automatically in three steps.

1. Test of each individual strut by lowering it 20 mm below its current level for a period of 30 seconds
2. Charge and empty the accumulator
3. Variation of electrical currents to actuate the shock absorbers

Final control diagnosis is implemented when the vehicle is stationary and the ignition is on. The engine may be running. During final control diagnosis, the yellow warning lamp in the dash panel insert flashes.

Each of the three steps may be selected separately (selective final control diagnosis).

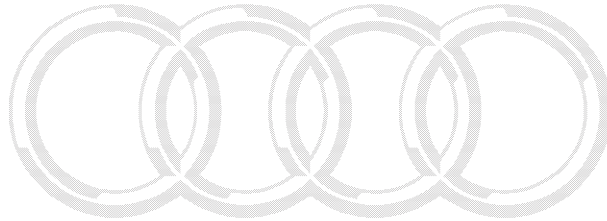

Audi

Measured value blocks

The most important information about the system status are stored in the measured value blocks.

Copyright. Copying, distribution, reproduction, or other use is not permitted unless authorised by AUDI AG. AUDI AG does not guarantee or accept any liability with respect to the correctness of information in this document. Copyright by AUDI AG.

Detailed information on system initialisation, final control diagnosis, measured value blocks and control unit coding can be found in the fault finding guide.

erwin



	Notes		

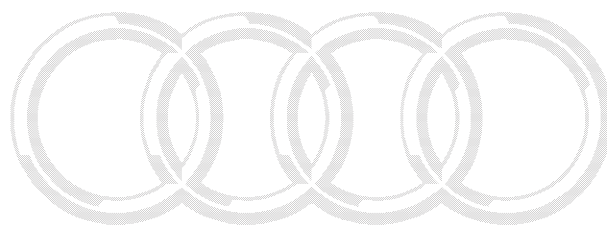

Audi

Protected by copyright. Copying for private or commercial purposes, in part or in whole, is not permitted unless authorised by AUDI AG. AUDI AG does not guarantee or accept any liability with respect to the correctness of information in this document. Copyright by AUDI AG.



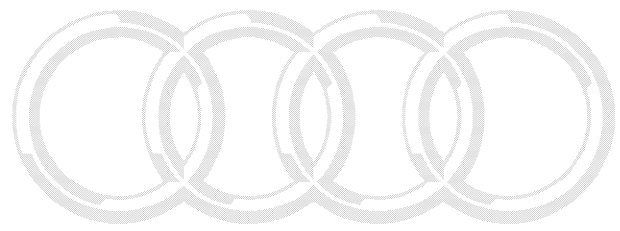

Audi

Protected by copyright. Copying for private or commercial purposes, in part or in whole, is not permitted unless authorised by AUDI AG. AUDI AG does not guarantee or accept any liability with respect to the correctness of information in this document. Copyright by AUDI AG.

erWin 



Audi

Protected by copyright. Copying for private or commercial purposes, in part or in whole, is not permitted unless authorised by AUDI AG. AUDI AG does not guarantee or accept any liability with respect to the correctness of information in this document. Copyright by AUDI AG.

er/Man 

All rights reserved, including the right to
make technical changes
Copyright* 2002 AUDI AG, Ingolstadt
Department I/VK-35
D-85045 Ingolstadt
Fax +49 (0)841/89-36367
000.2811.12.20
Technically correct as at 007/02
Printed in Germany