

Removing and installing turbocharger - engine codes BRD and BVA

Caution

If the turbocharger has suffered mechanical damage (e.g. damaged compressor wheel), it is not sufficient merely to fit a new turbocharger. The following work must be performed in order to avoid further damage:

- t Check air cleaner housing, air filter element and air intake hoses for dirt and foreign particles.
- t Check the entire charge air system (including the charge air cooler) for foreign matter.
- t If foreign matter is found in the charge air system, clean all relevant ducts and hoses and renew charge air cooler if necessary.

Removing

- Open quick-release fasteners -1 □ 3- and take off front and rear noise insulation.

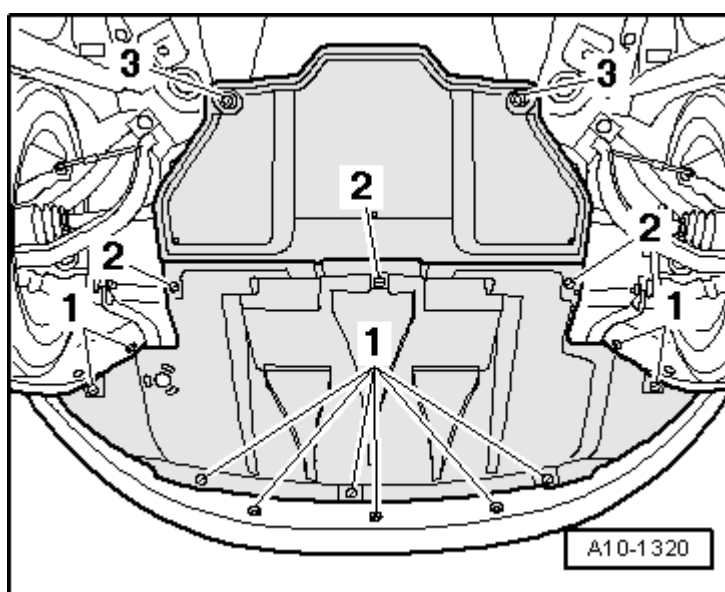

- Disconnect exhaust system at clamp - arrow-.

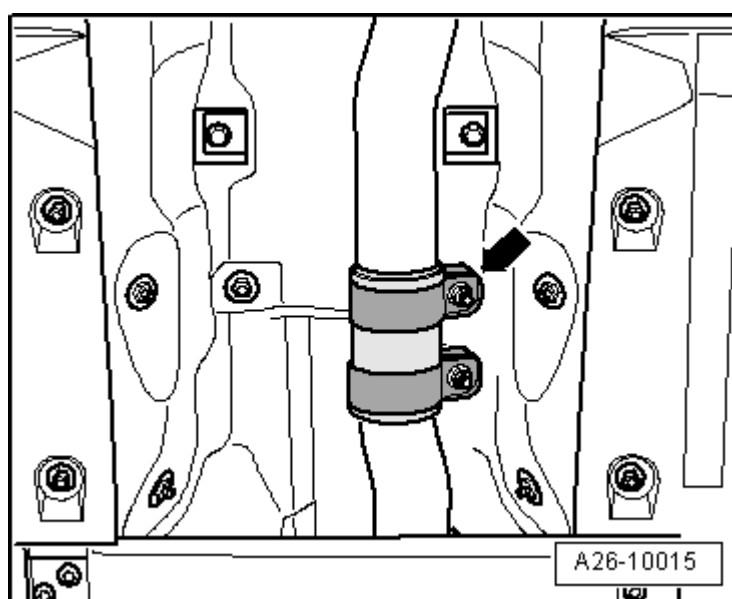

- Disconnect air intake hose from turbocharger -arrow-.

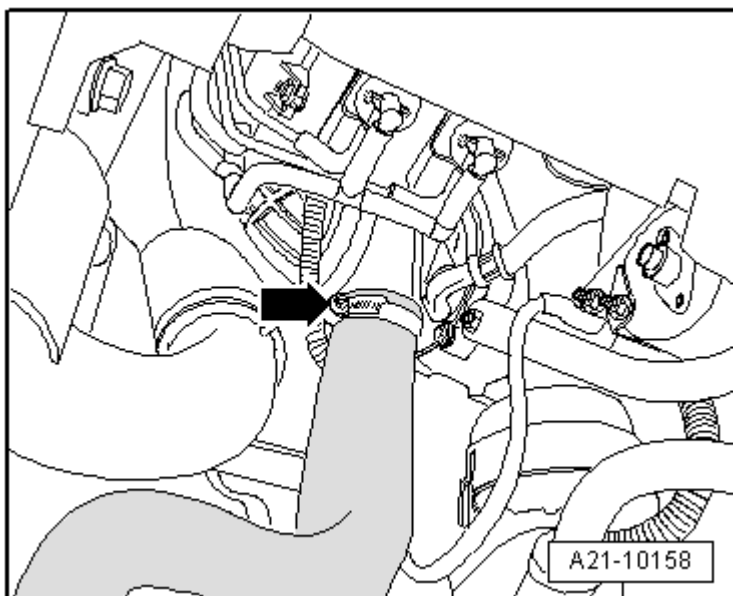

- Remove bolts -1- and -2- and detach support for turbocharger.

i Note

Place a cloth underneath to catch any escaping oil.

- Remove oil return pipe -3- at cylinder block.

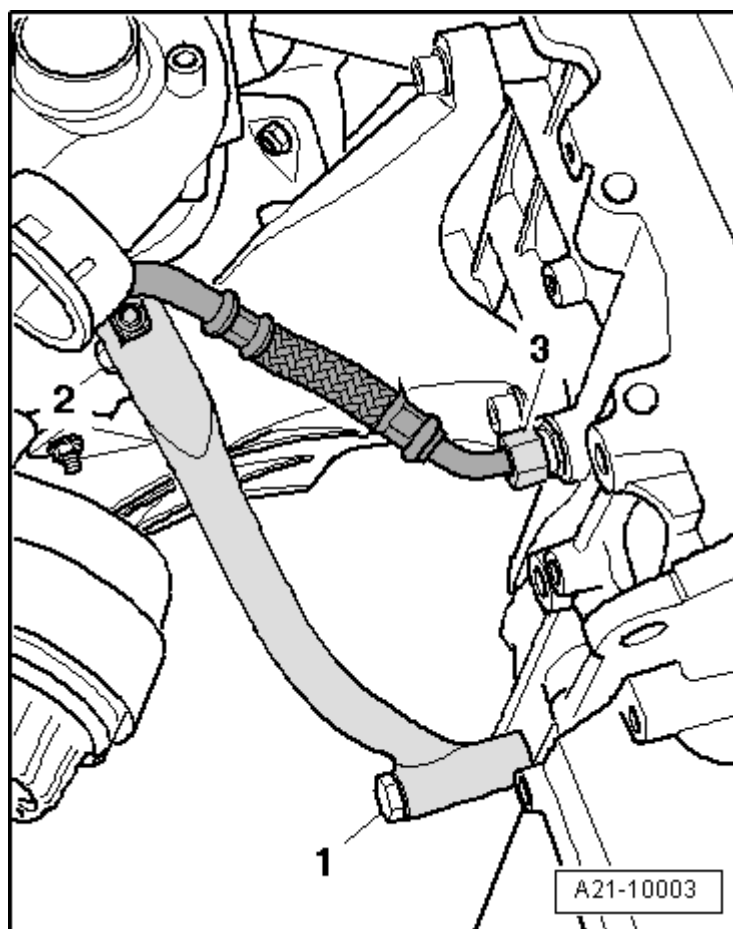

- Unscrew nuts -2- and -3- (accessible from below) connecting turbocharger to exhaust manifold.

i Note

Disregard -item 1-.

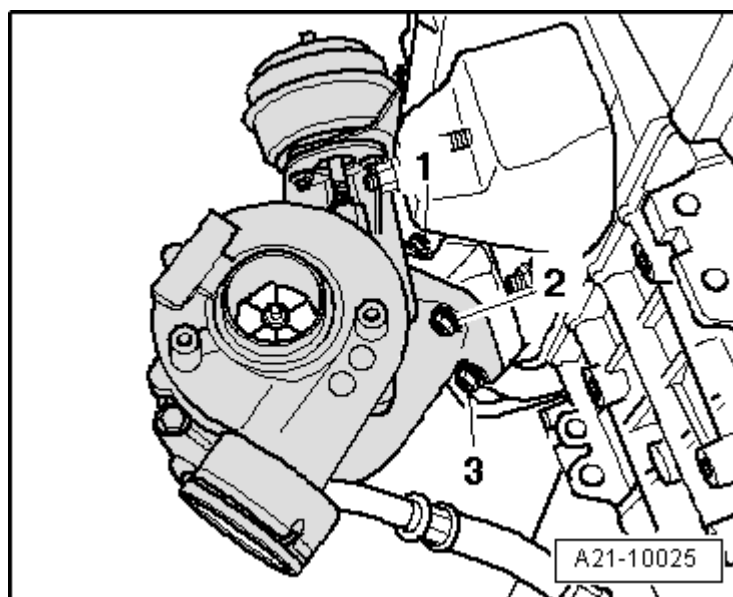

- Pull off engine cover panel -arrows-.

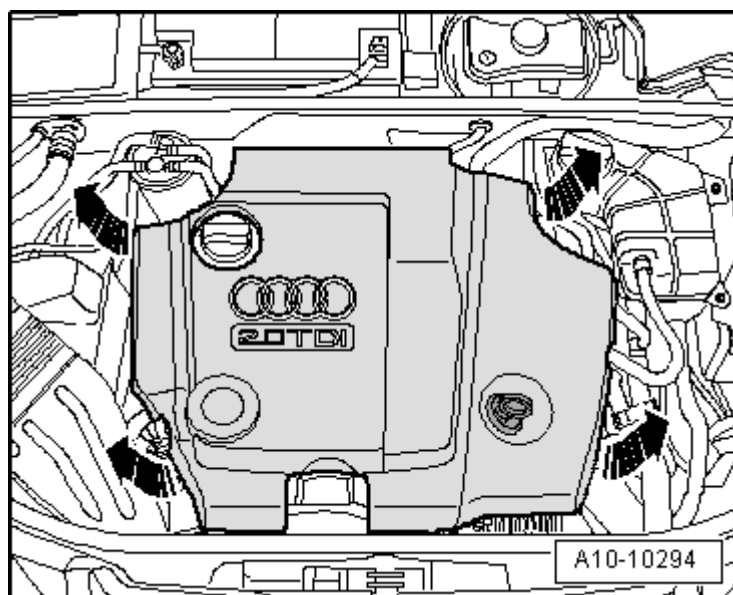

- Remove bolts -arrows-.
- Remove air ducts -1- and -2-.

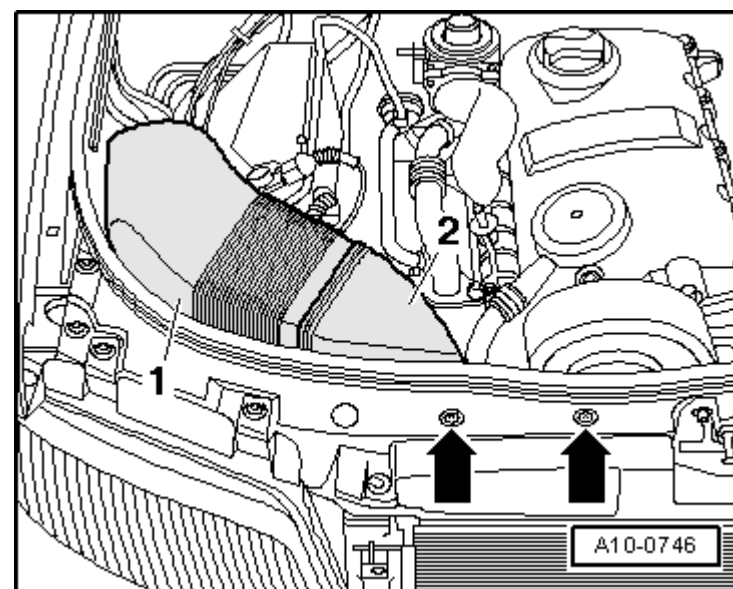

- Unplug electrical connector -1- at air mass meter -G70-.

- Loosen hose clip -2- to remove air intake hose.
- Move clear wiring harness at air cleaner housing and remove air cleaner housing - arrow-.

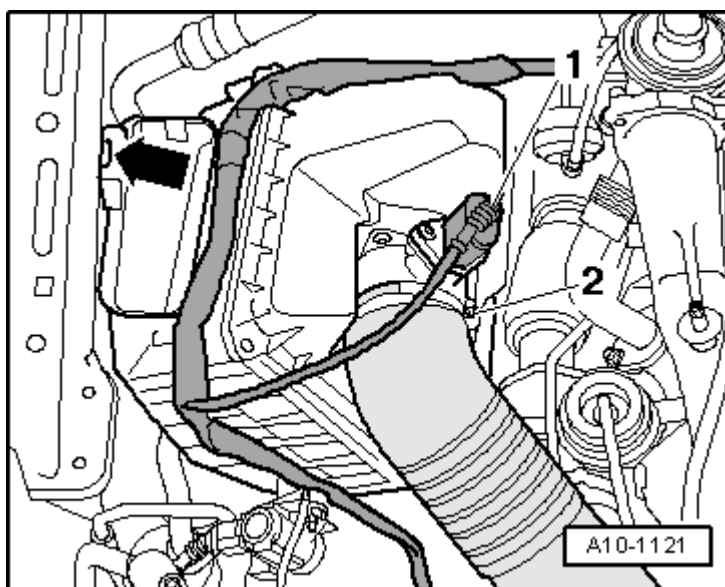

- Detach crankcase breather hose -2- from cylinder head cover.
- Remove bolts -3- and -4-.
- Detach hose -1- between charge air cooler and turbocharger.

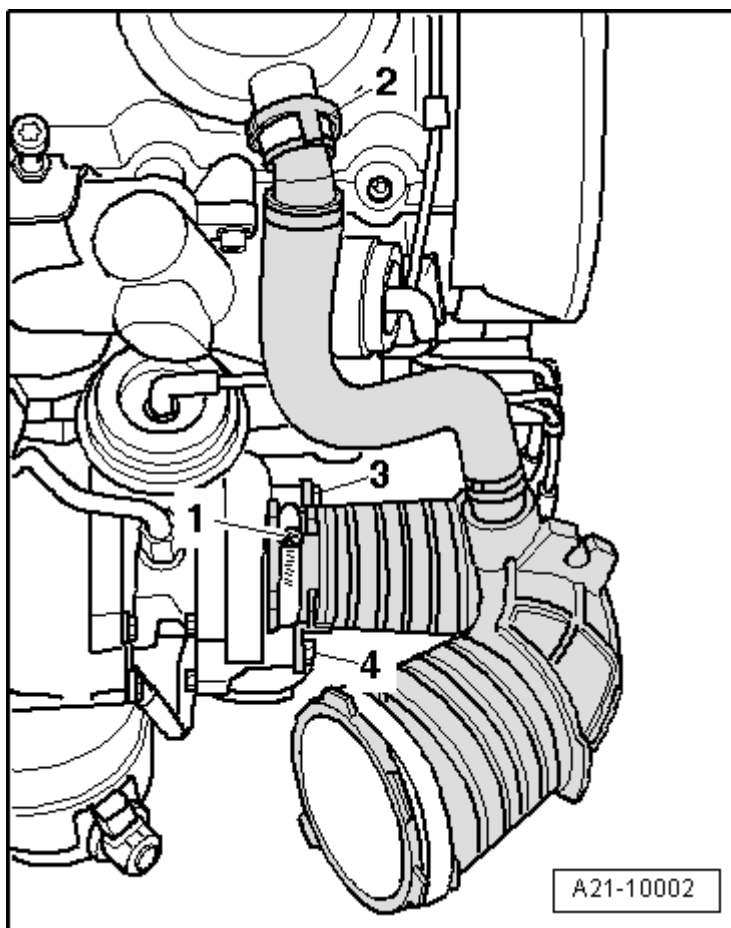

- Detach vacuum line -3-.

Note

Disregard items marked -1- and -2-.

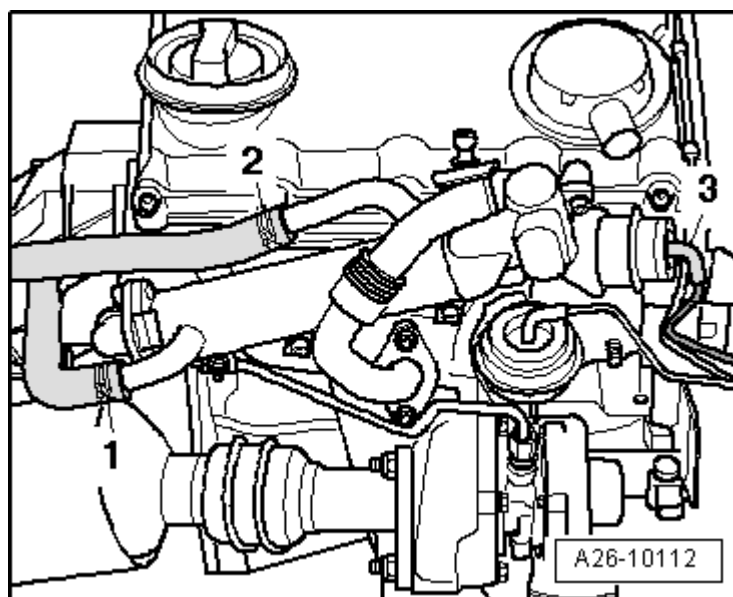

- Unscrew bolts -1- and nuts -2-.
- Remove bolts -arrows-.
- Remove exhaust gas recirculation cooler and lay it aside with coolant hoses connected.

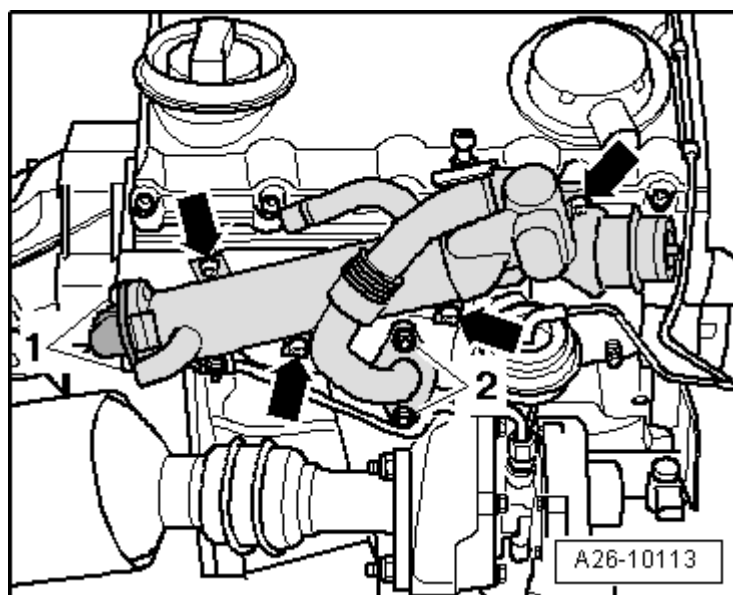

- Detach vacuum hose -3-.
- If fitted, unplug electrical connector -2- at position sender for charge pressure positioner -G581-.
- Unscrew exhaust gas temperature sender 1 -G235--item 1-.

Note

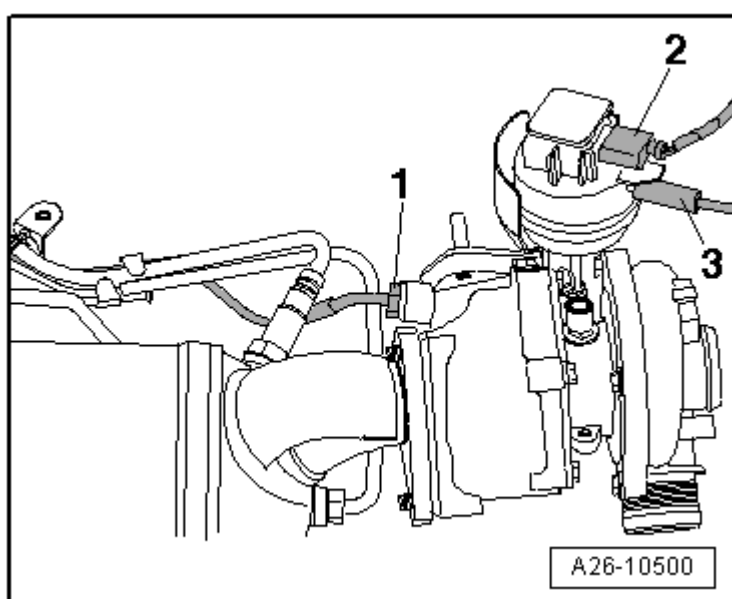

To avoid any damage, the flexible joint in the

front exhaust pipe must not be bent more than 10°.

- Unscrew nuts on turbocharger -arrows- and detach particulate filter from turbocharger.

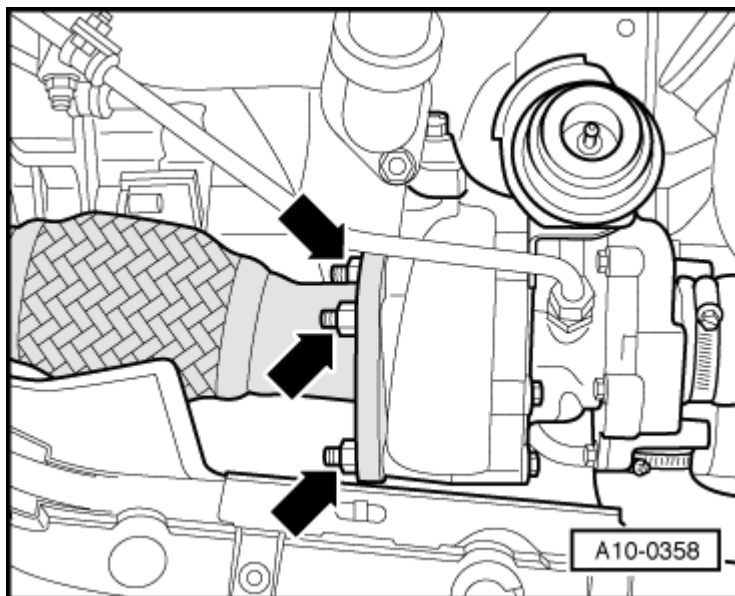

- Unscrew oil supply pipe at turbocharger and exhaust manifold -arrows-.

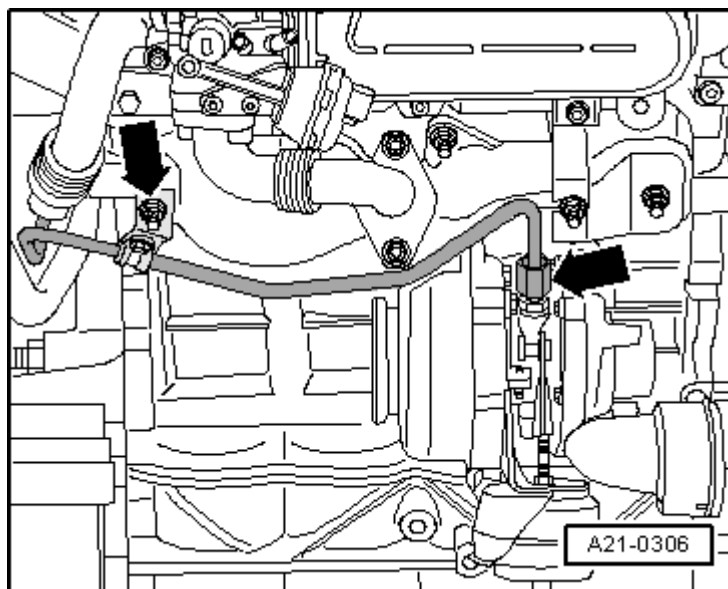

- Unscrew securing nut accessible from above -1- connecting turbocharger to exhaust manifold and remove turbocharger.

Note

Disregard items marked -2- and -3-.

Installing

Installation is carried out in the reverse order; note the following:

Note

- t Renew gaskets, seals and self-locking nuts.
- t Fill turbocharger with engine oil at connection for oil supply pipe.
- t Charge air system must be free of leaks.
- t Hose connections and hoses for charge air system must be free of oil and grease

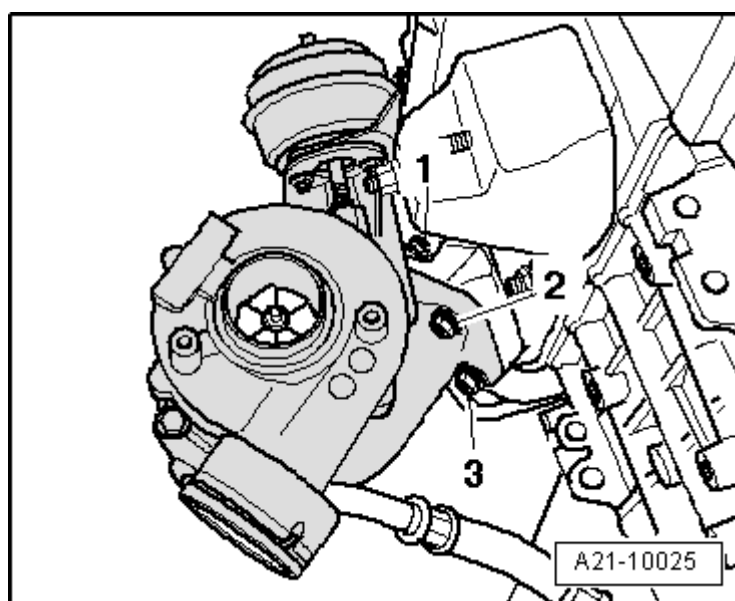

before assembly.

- t Secure all hose connections with the correct type of hose clips (same as original equipment) → [Electronic parts catalogue](#).
- t To ensure that the charge air hoses can be properly secured at their connections, spray rust remover onto the worm thread of used hose clips before installing.
- Install exhaust temperature sender 1 - G235- → [Chapter](#).
- Install exhaust gas recirculation cooler → [Chapter](#).
- Install particulate filter: vehicles with manual gearbox → [Chapter](#); vehicles with multitronic gearbox → [Chapter](#).
- Align exhaust system so it is free of stress → [Chapter](#).
- Check oil level → [Booklet803](#) or → [Booklet805](#).

 **Note**

After installing turbocharger, allow engine to idle for approx. 1 minute and do not rev up immediately to ensure turbocharger is supplied with oil.

Tightening torques

Component	Nm
Turbocharger to exhaust manifold	25 ¹⁾²⁾
Support for turbocharger to turbocharger	20
Support for turbocharger to cylinder block	40
Oil return pipe to cylinder block	40
Oil supply pipe to turbocharger	22
Bracket for oil supply pipe to exhaust manifold	22
Air intake hose to turbocharger	8
Hose clips (9 mm wide)	3.5
Hose clips (13 mm wide)	5.5
¹ 1) Renew nuts. ¹ 2) Coat threads and contact surface with high-temperature paste; for high-temperature paste refer to → Electronic parts catalogue .	