

Removing and installing moulded headliner - Saloon

Special tools and workshop equipment required

- ◆ Removal lever -80 - 200-

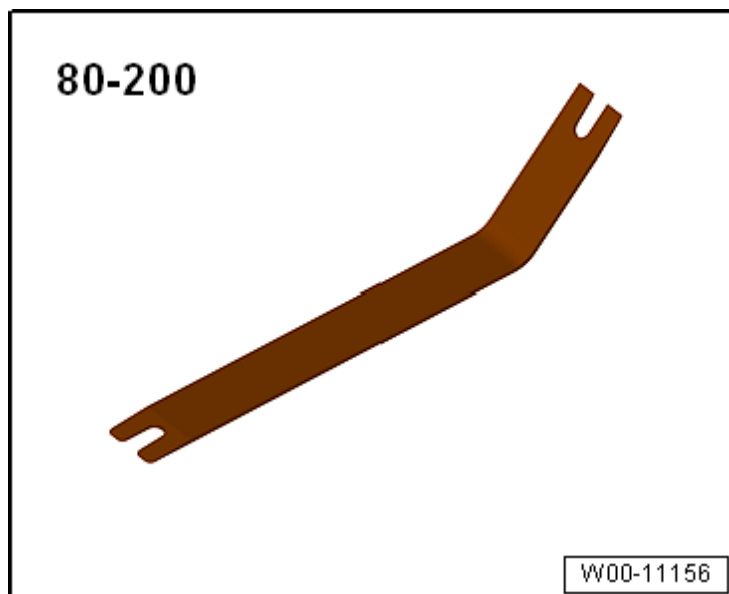

- ◆ Removal wedge -T40233-

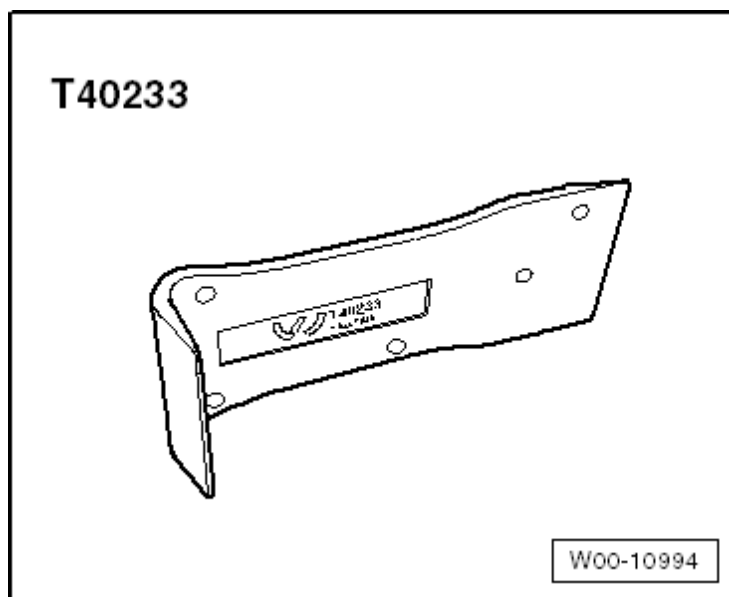

- ◆ Removal tool -T40280-

Removing

 **WARNING**
*Observe safety precautions when working on pyrotechnic components → **Chapter**.*



Equipment version with sliding sunroof:

- Fully open sunroof -1-
- Open sun blind -2- approx. $\frac{2}{3}$.

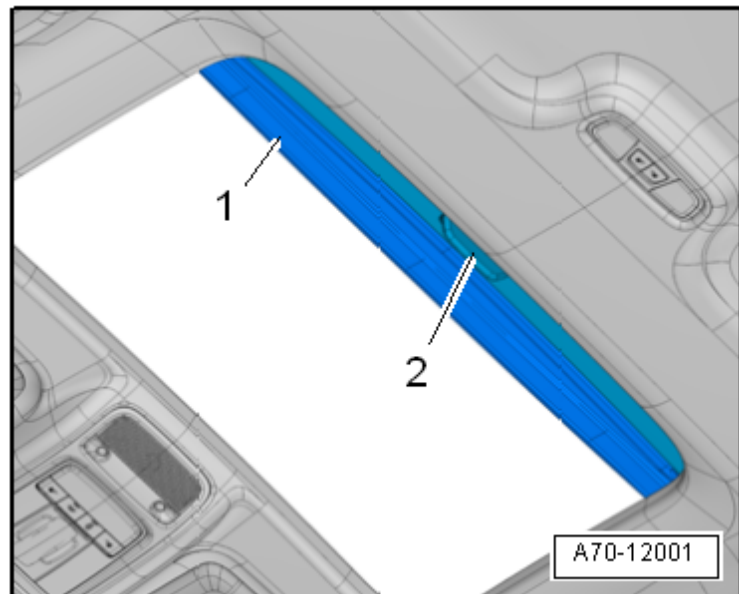

- Clean removal wedge -T40233- to avoid soiling moulded headliner.
- Insert removal wedge -T40233- between trim frame -2- for sunroof opening and moulded headliner.
- Release trim frame from retainers -1- one after the other using removal wedge - T40233- as shown -arrows-.

All vehicles (continued):

- Remove passenger side door → [General body repairs, exterior; Rep. gr.57; Door; Removing and installing door.](#)
- Remove front passenger's seat → [Chapter.](#)

- Remove A-pillar trim panels (top) → Chapter.
- Remove B-pillar trim panels (top) → Chapter.
- Remove D-pillar trim panels → Chapter.
- Remove C-pillar trim panels → Chapter.
- Remove centre console → Chapter.
- Remove roof module (front) → Electrical system; Rep. gr.96; Controls; Overview of fitting locations - controls in roof trim.
- Equipment version with front camera:
Remove cover for front camera → Anchor.
- Remove light for make-up mirror → Electrical system; Rep. gr.96; Lights; Overview of fitting locations - lights in roof trim.
- Remove sun visors → Chapter.
- Remove centre bracket for sun visor → Chapter.
- Remove grab handles → Chapter.
- Move steering wheel forwards and upwards as far as possible, using full range of steering column adjuster.

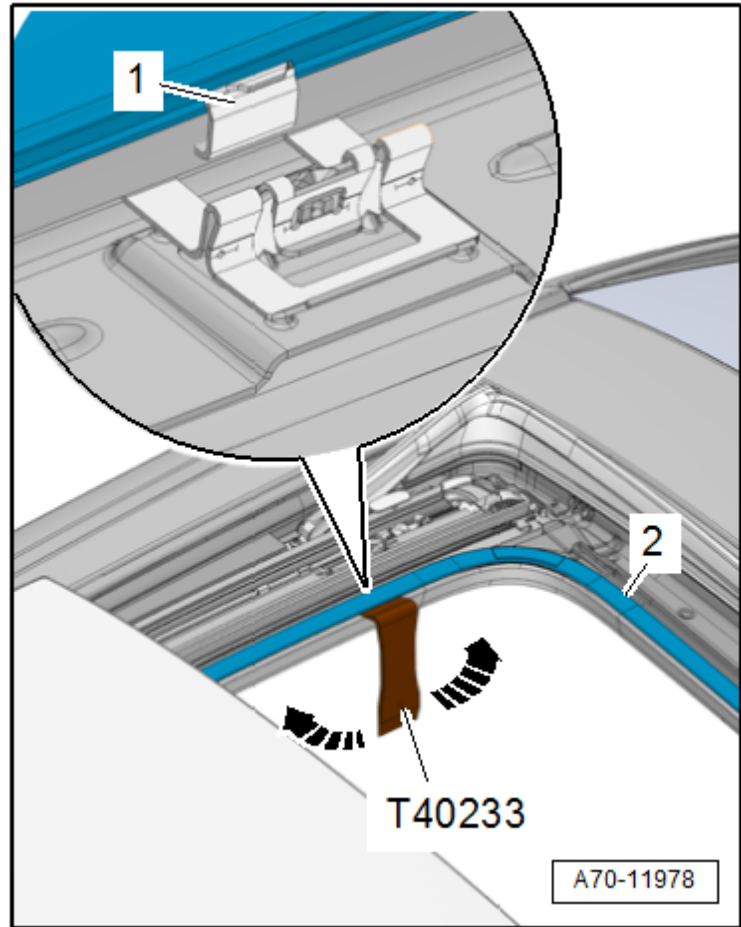

- Move driver's seat as far forwards and down as possible and tilt backrest as far back as possible.



Caution

- ◆ **The moulded headliner is kinked very easily.**
- ◆ **Kinked moulded headliners must be renewed.**

- Unclip moulded headliner (rear) from clips -1 and 3- on body -arrows- using removal lever - 80 - 200-.
- Unclip moulded headliner from body at rear at centring pin -2-.



Note

Take out moulded headliner through front passenger door.

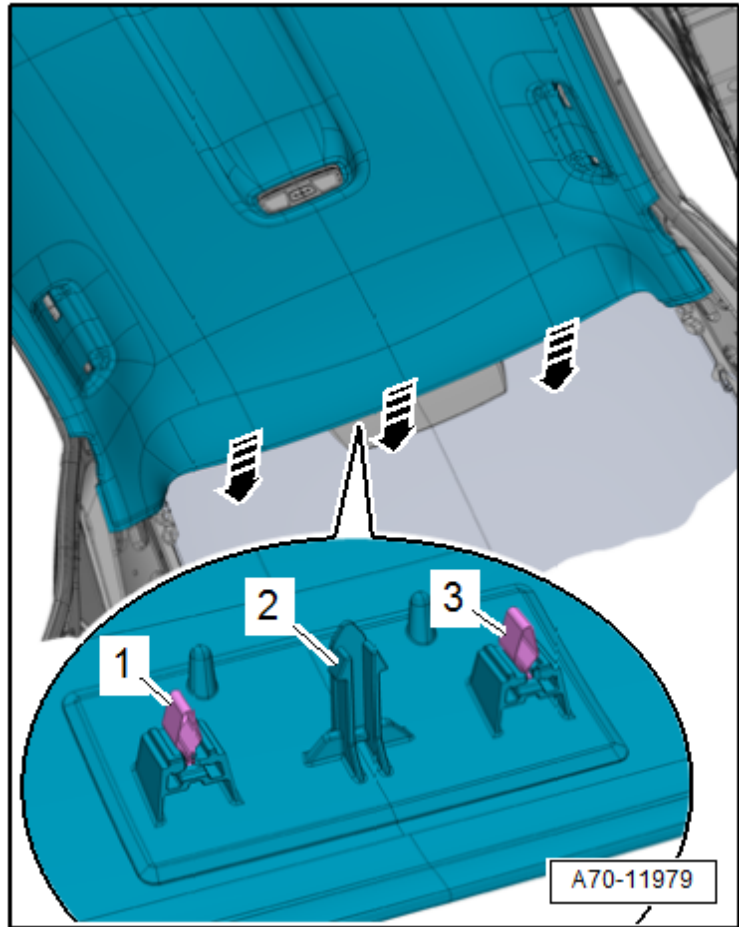

- Open rear door (left-side).
- Lower moulded headliner -1- at front and turn it towards opening for front passenger door (tilt left side downwards).
- Take out moulded headliner through front passenger door, as shown.

Installing

 **WARNING**
Observe safety precautions when working on pyrotechnic components → Chapter.

- Align moulded headliner centrally and press centring pin at rear of moulded headliner into mounting point in body until it engages audibly.
- Install centre bracket for sun visor → Chapter.
- Press clips at rear of moulded headliner into mounting points in body until they engage audibly.

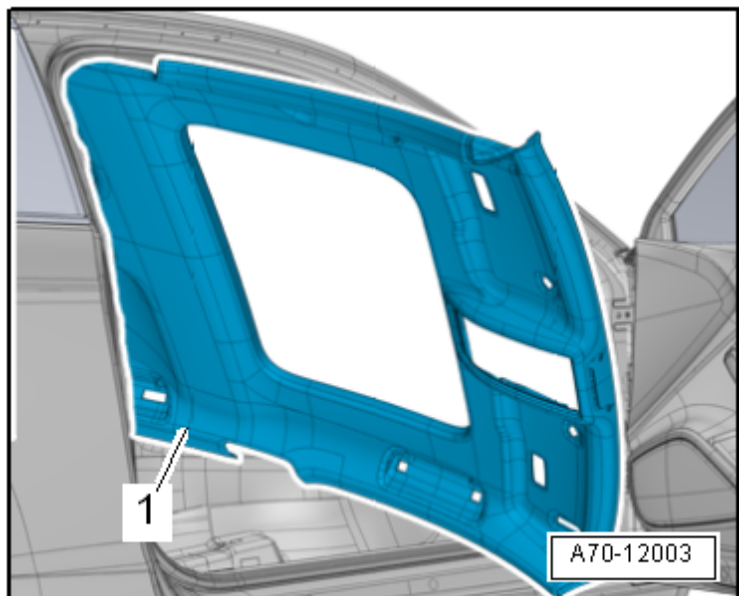

Perform remaining installation in reverse order of removal.

Notes for installation: tightening torques, renewing components etc. → Chapter „Exploded view - moulded headliner“