

Removing and installing high-level brake light bulb - M25- - Saloon

Removing

- Do not press brake pedal.
- Detach moulded headliner from body in area of high-level brake light → [General body repairs, interior; Rep. gr.70; Roof trim panels; Removing and installing moulded headliner.](#)
- Pull off high-level brake light -2- by moving cover evenly towards rear of vehicle -arrows-
- Unplug electrical connector -1-.

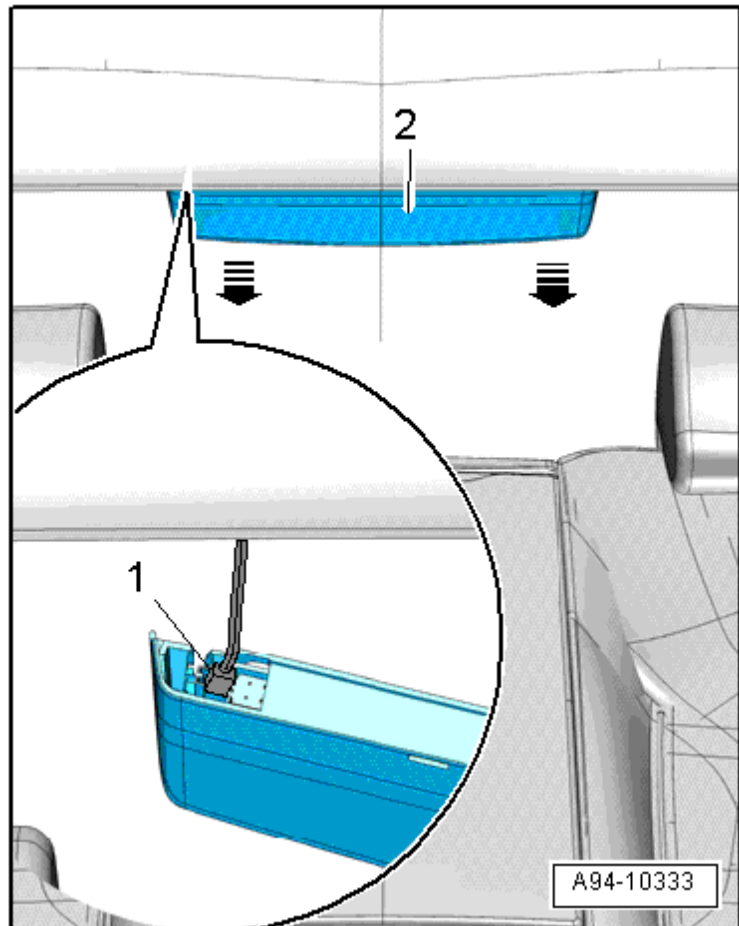

Installing

Installation is carried out in the reverse order; note the following:



Note

Entire high-level brake light must be renewed if LED is defective.

- The mounting -2- of the high-level brake light -3- must engage evenly in guide rail -1- on both sides.
- Slide high-level brake light evenly to front in direction of travel until it is heard to engage, taking care to keep it straight -arrows-.

