



Schematics Primer - Audi 80/90 Models

All B3 & B4 Platforms 1987 – 1996
include Coupe, Cabrio, Sedan, Avant, S2 & RS2

A demystifying guide to schematics & cabling

Paul Nugent, 1st August 2009



Schematic Introduction

No. 50/1 Current Flow Diagram Audi 80

Battery, starter, alternator

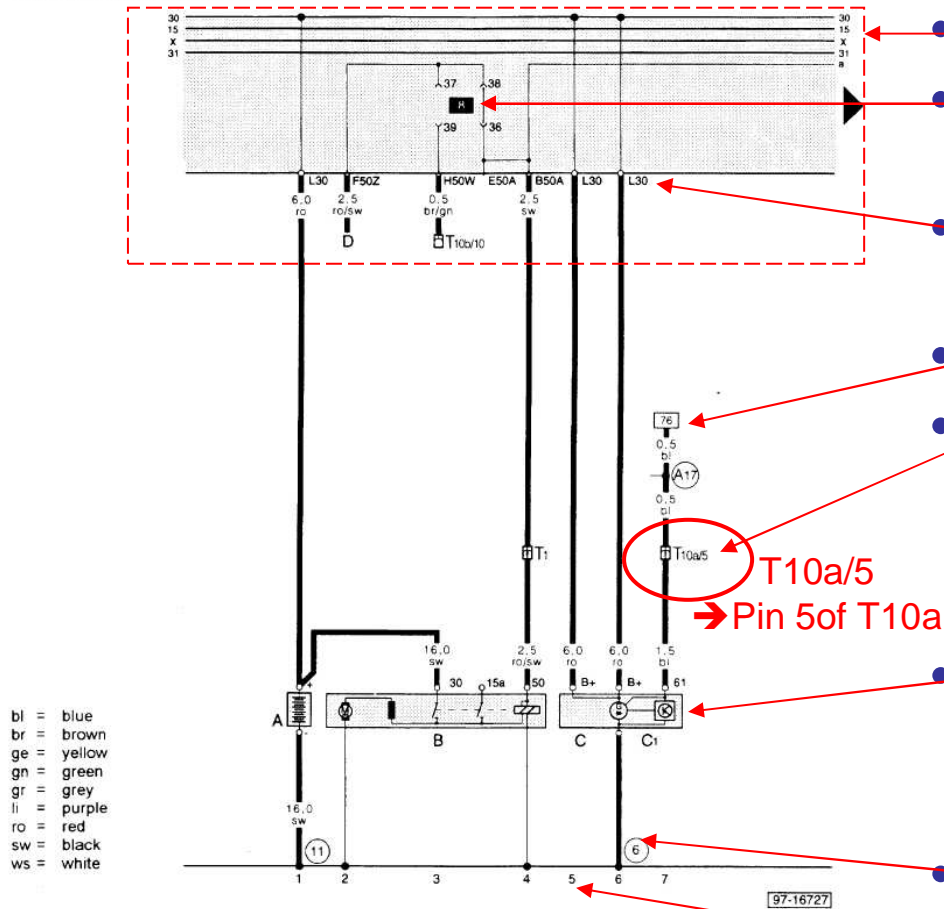

- This area is the main fuse panel
- This is a numbered relay location in the main fusebox / electric panel
- These denominations are printed on the underside of main fusebox
- Links to another current track
- Connectors along the way
 - Always starts with a **T** label
 - Next digit determines the number of pins on the connector block
- Electrical components – usually annotated with correct pin numbers
- Earth Points (0V)
- Current track numbers



The main fusebox & wire colours

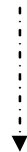
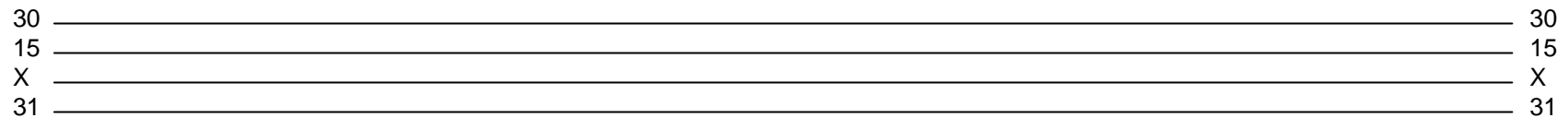

30 = Permanent 12V feed (Battery +ve)

15 = Switched 12V feed (Ignition ON)

X = Switched 12V feed (Ignition ON)
extra capacity provided by X-relay
to reduce current thru ignition switch
when the key is turned ON.

31 = Earth (0V)

Wire Colour Codes

bl = Blue
br = Brown
ge = Yellow (Gelb)
gn = Green
gr = Grey
li = Lilac / Pink
ro = Red (Rot)
sw = Black (Schwartz)
ws = White (Weiss)

For all S2/RS2 schematics across the years and B3/B4 variants →

http://www.s2central.net/S2_Schematics/



Main Fusebox Layout on Schematic

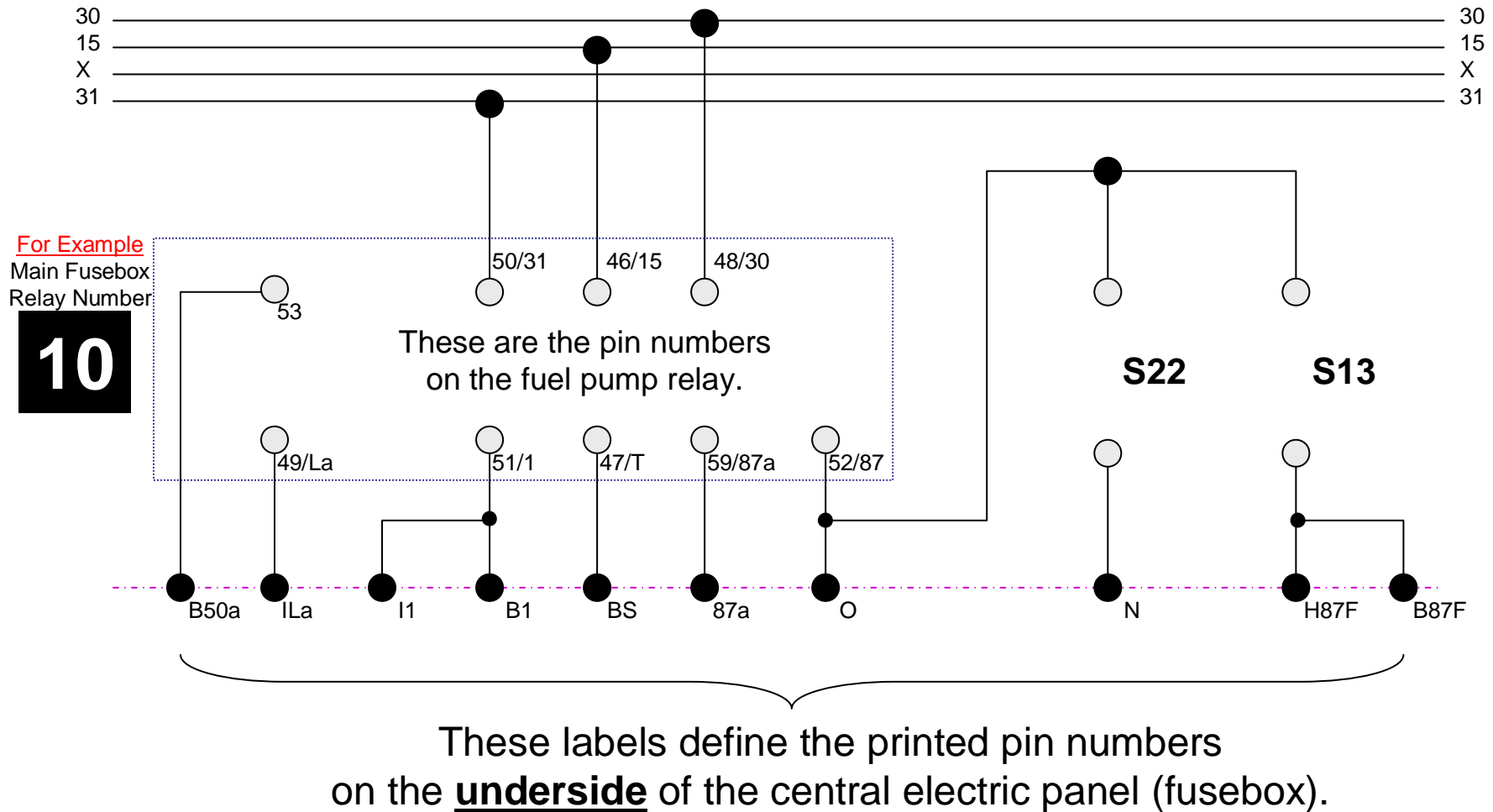



Common Audi Wiring Nomenclature

A = Battery

B = Starter

C = Alternator

D_n = Ignition Switch

E_n = Switch (User)

F_n = Switch (Other)

G_n = Sensor / Sender

H_n = Horn / Sounder

J_n = Electronic Module

K_n = Warning bulb

M_n = Light bulb

N_n = Actuated device

Q_n = Spark Plug

S_n = Fuse

T_n = Connector Terminal

V_n = Motor

NOTE - This list is not exhaustive – just an introduction / general guide



Main Fusebox / Relay Plate

- All B4 models
 - 80 Sedan / Avant
 - Including S2 & RS2
- Early B3 models
 - Coupe/Cabrio up to May '92

A = K-wire eyelet
B = L-wire eyelet

C = Black OBD
D = White OBD (K/L)
E = Blue OBD (MIL)

F = Additional Fuses (23-32)
G = Main Fuses (1-22)
H = Spare Fuses (4-off)

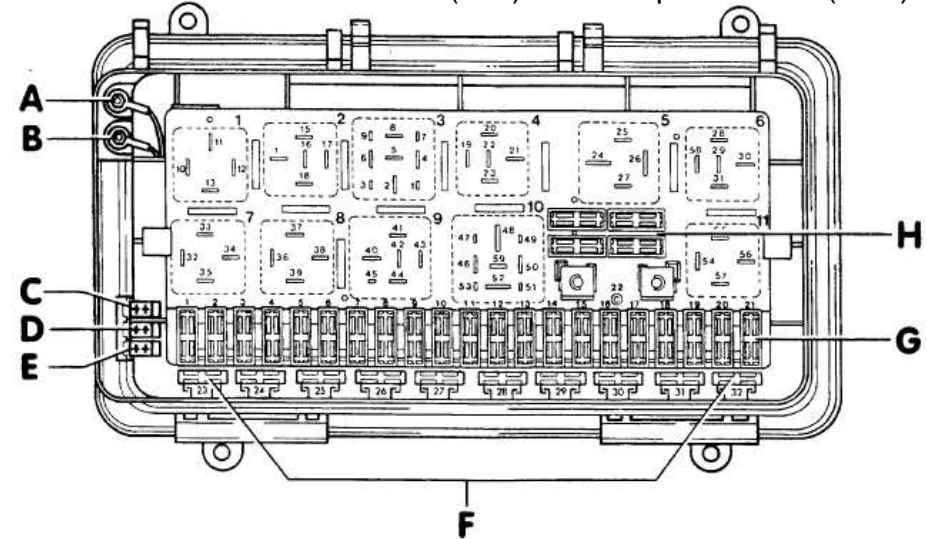

- Late B3 models
 - From May '92 onwards
 - Note A & B eyelets swapped
 - Doesn't really matter as long as you don't mix up K & L
 - Seems wrong as you'd think that all B4 would be same as late B3 but its bass ackwards

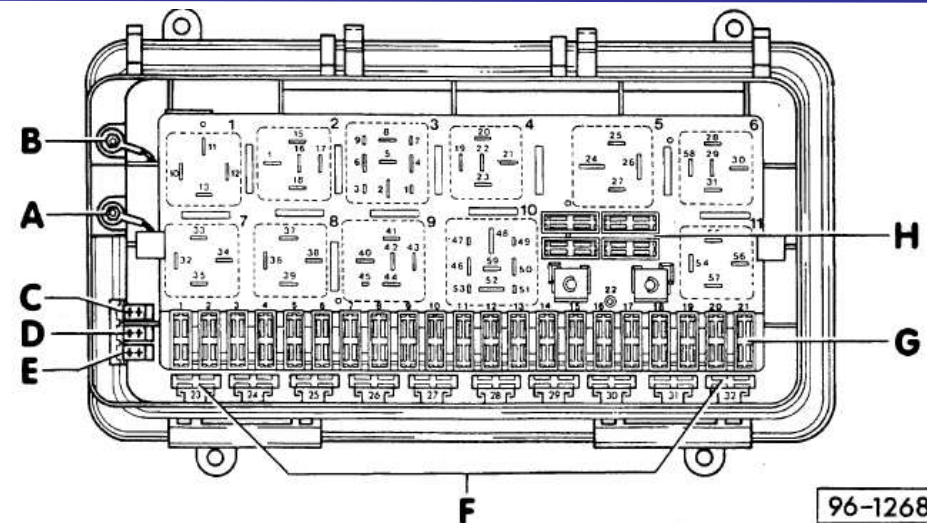



Central Electric Panel (CEP)

- Clips into the main fusebox housing
- Holds 11 relays & 21 fuses
 - 22 fuses if you include a diesel app
- Generic part number = **443 941 822A**
 - Older part numbers include 443 941 822B which can be superseded by the 'A' part
 - Applicable to just about all Audi models from 1980 through to 1996 (except A4, A8)
- There are 59 uniquely numbered pins
 - Note that earlier variants may not include all the terminals needed for the plug and play installation of a 3B or ABY / ADU engine wiring loom
 - The photo here is of the older 'B' panel and it does have all the required pins.
 - Note pins 58 and 59 are out of step...
 - 58 at Relay position #6. This is part of the manual air conditioner circuit.
 - 59 at Relay #10, is a switched feed to 3B and ABY/ADU components.

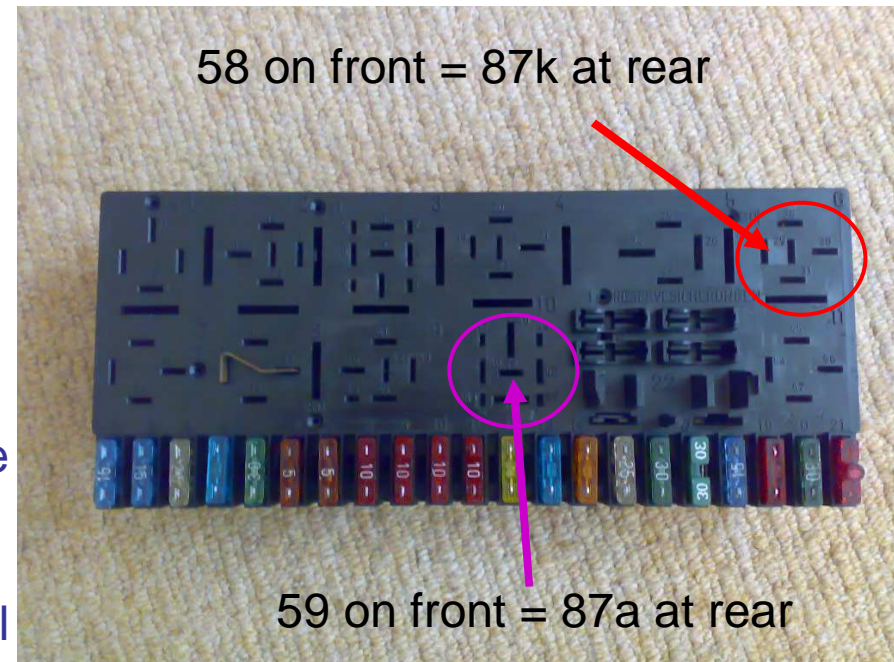

**See ABY wiring documents
for more information**



Underside of CEP

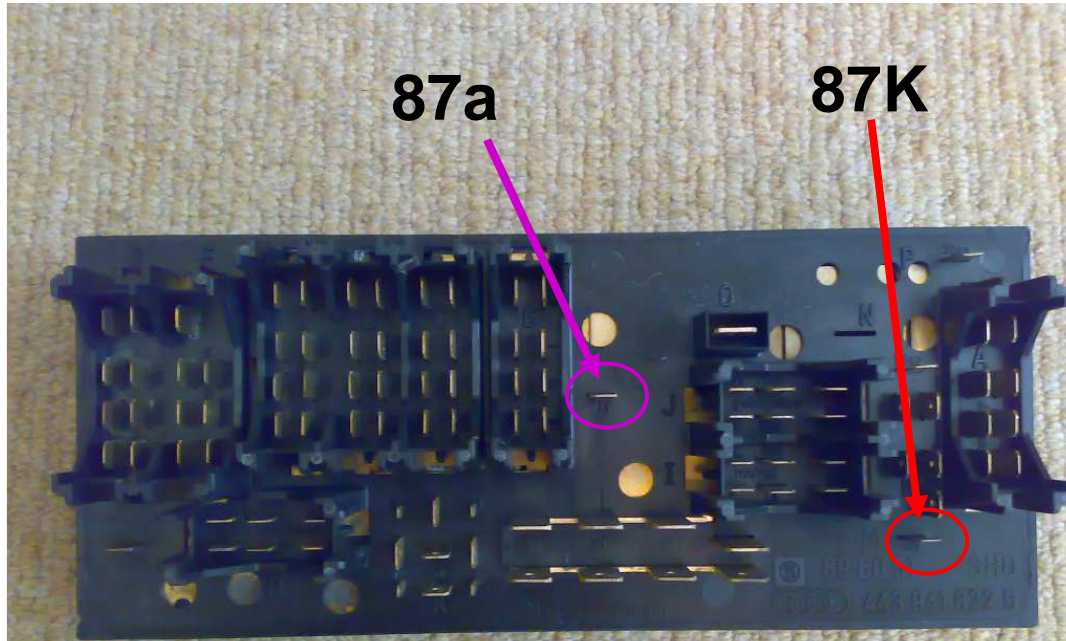

- A – Grey (air conditioner)
- B – Black (front right/engine)
- C – Blue (dashboard)
- D – Green (front left)
- E – Yellow (also front left)
- F – Brown (dashboard)
- G – Red (dashboard)
- H – Black (rear)
- I – Red (dashboard)
- J – Yellow (dashboard)
- K – Black (for relay #3)
- L – Terminal 30 (+12V)
- M – Various singles, options
- N – Glow plugs (diesel only)
- O – Output from relay #10
- P – Output side of fuse #20

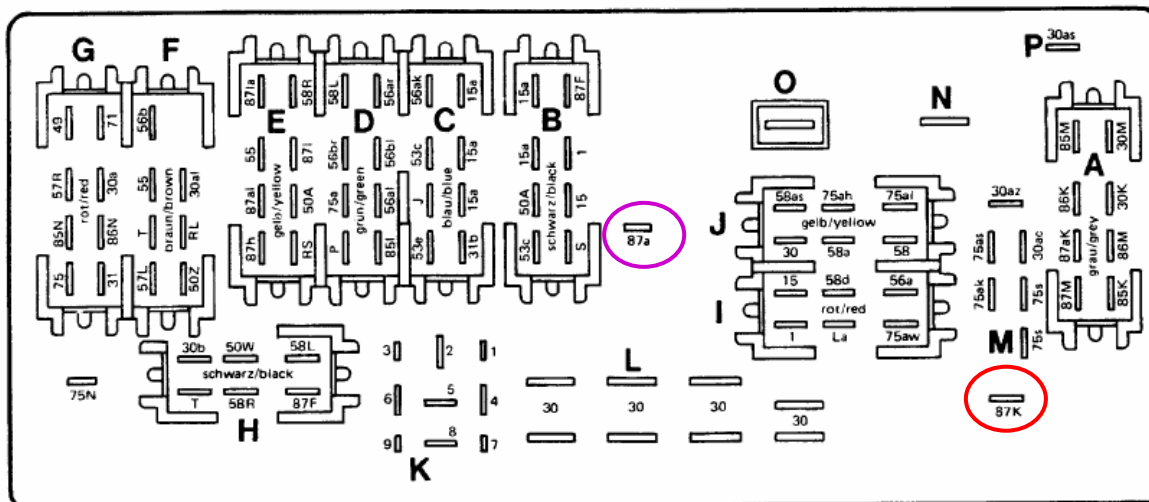



Front Auxiliary Relay Panel - LHD

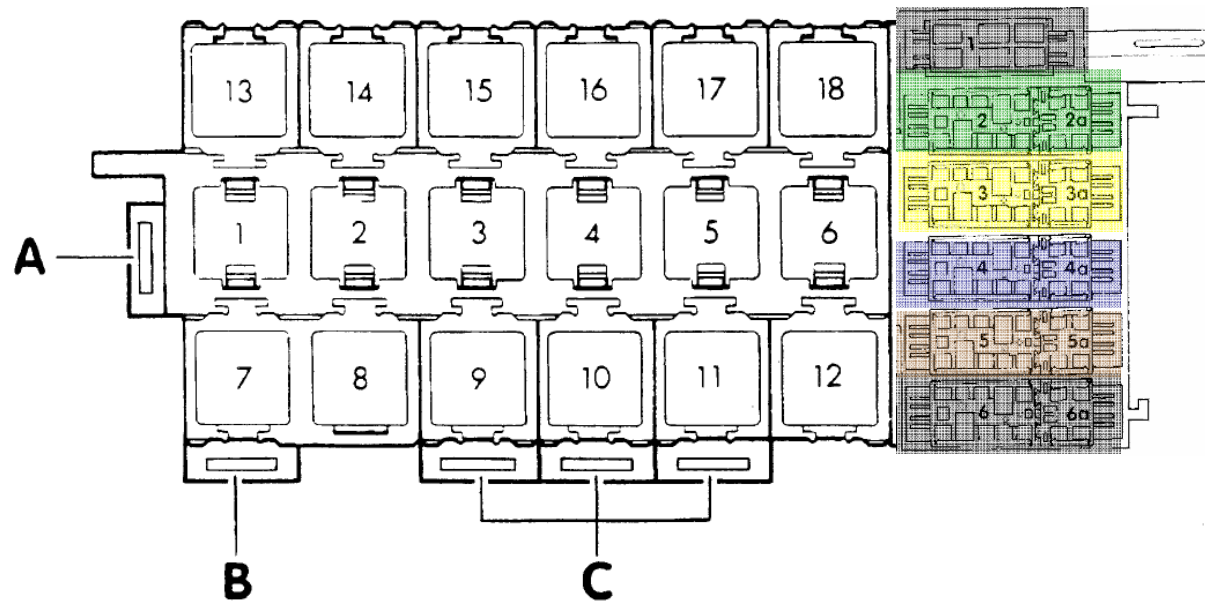

Multi-pin plug assignments

- 1 – Black, wiper motor
- 2 – Green, automatic box
- 2a – Green, aircon
- 3 – Yellow, Loom front left
- 3a – Yellow, Heated seats
- 4 – Blue, ABS
- 4a – Blue, Cruise Control
- 5 – Brown, Loom rear
- 5a – Brown, Door switches
- 6 – Black, Loom front / engine
- 6a – Black, Loom front / engine

- Located in drivers side footwell below dashboard
 - A & B are fuse locations for the radiator fan
 - C are locations for the thermal fuses (windows, sunroof)



Front Auxiliary Relay Panel - RHD

Multi-pin plug assignments

- A – Black, wiper motor
- B – Green, automatic box
- B1 – Green, aircon
- C – Yellow, Loom front left
- C1 – Yellow, Heated seats
- D – Blue, ABS
- D1 – Blue, Cruise Control
- E – Brown, Loom rear
- E1 – Brown, Door switches
- F – NOT USED
- G – Black, Loom front / engine
- G1 – Black, Loom front / engine

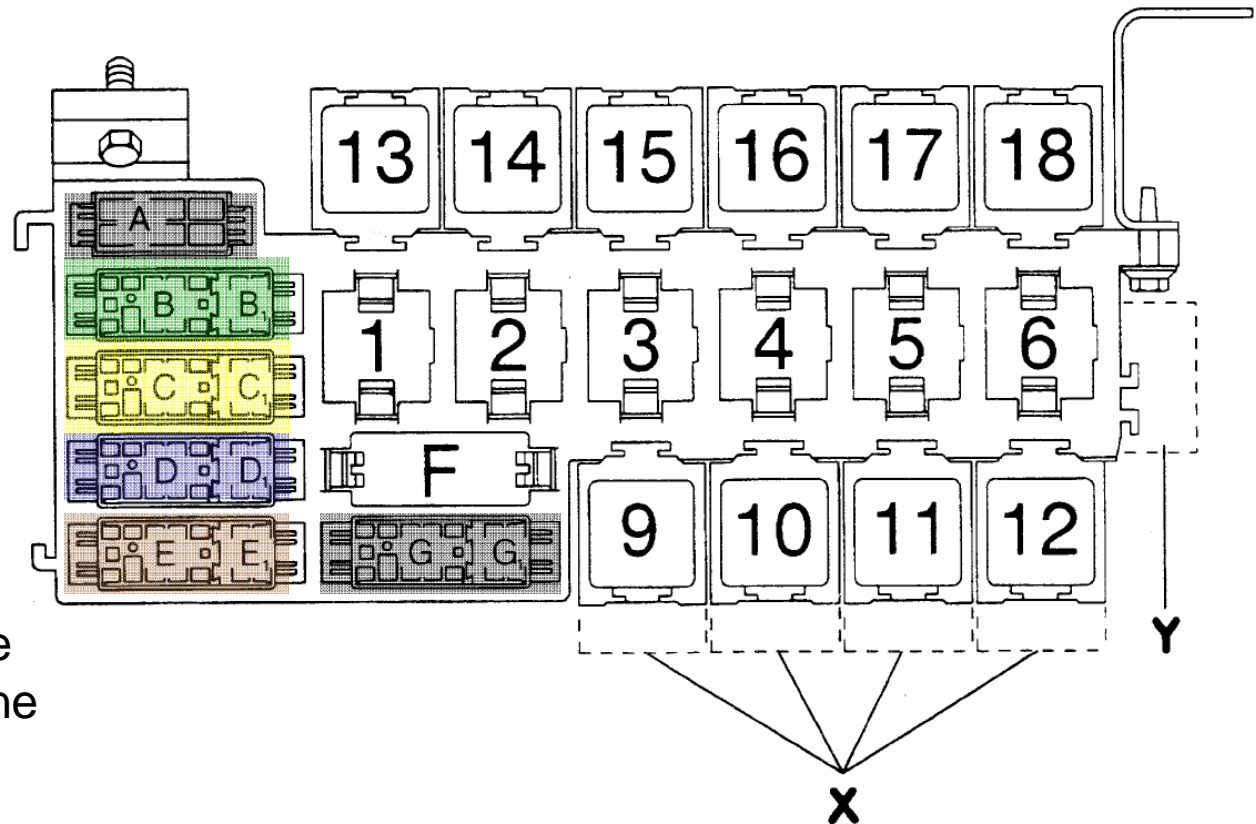

- Located in drivers side footwell below dashboard
 - X are locations for the thermal fuses (windows & sunroof)
 - Y is the fuse location for the radiator fan



Rear Auxiliary Relay Panel

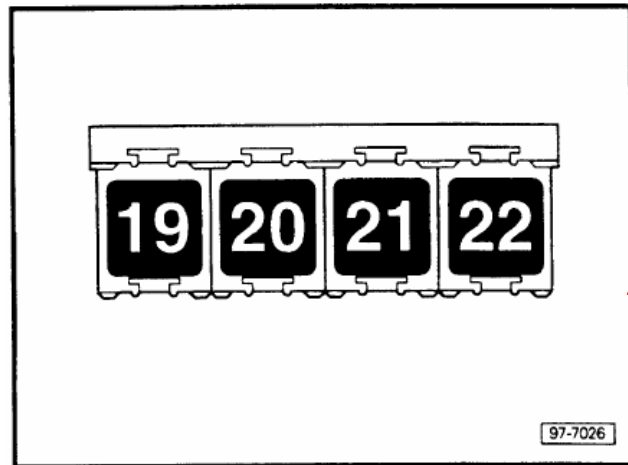

Located underneath rear seat

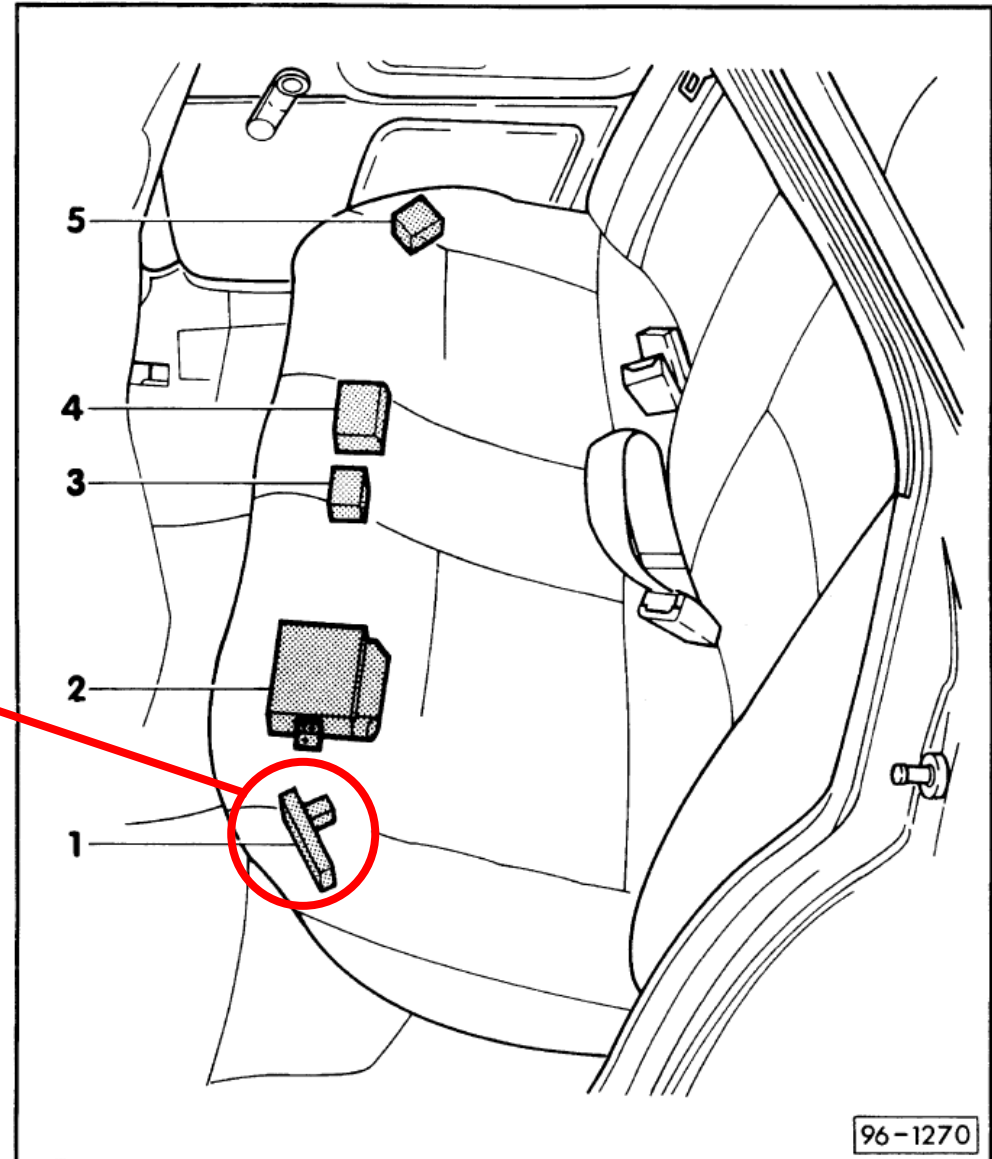



END

**Specific fuse and relay installations
are covered in another document.**

**Please send any comments,
questions or corrections to
S2central@mac.com**