

## Removing and installing guide link

### Special tools and workshop equipment required

- ◆ Engine and gearbox jack -V.A.G 1383 A-

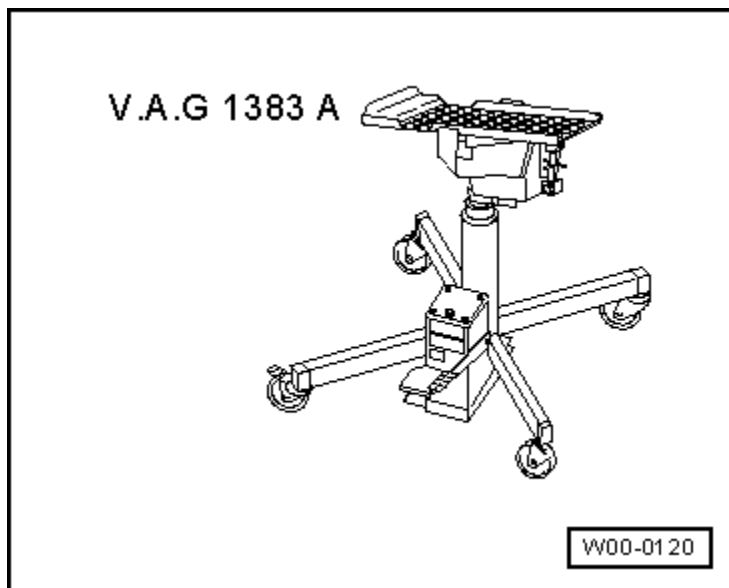

- ◆ Ball joint puller -T40010-
- ◆ Torque wrench -V.A.G 1332-

### Removing

- Remove wheel trim; on light-alloy wheels, pull off trim cap (use puller in vehicle tool kit).
- Remove wheel.
- Secure brake disc with one wheel bolt.
- If ball joint puller -T40010- cannot be inserted, detach brake caliper and secure on body.

#### Note

- ◆ *To prevent damage to brake line, attach brake line bracket to brake caliper HP-2 before securing brake caliper to body.*
- ◆ *Secure brake caliper to body so that weight of brake caliper does not overload or damage brake hose or brake pipe.*
- Unscrew nut on joint pin of guide link until it is flush with end of thread. Counterhold joint pin with 4 mm Allen key if necessary.
- Press joint pin of guide link out of tapered seat using ball joint puller -T40010-.

#### Note

- ◆ *Take care not to damage drive shaft boot.*
- ◆ *Make sure the two lever arms of the puller are parallel when maximum force is exerted.*

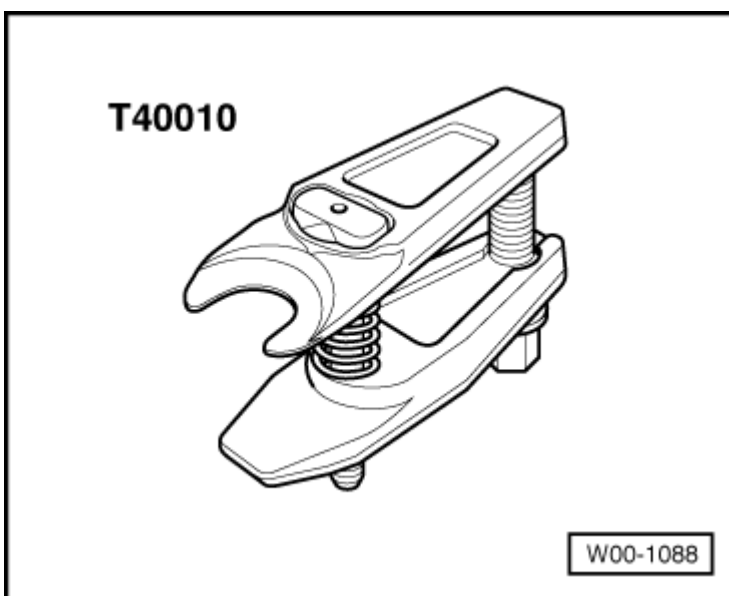

- Position engine and gearbox jack - V.A.G 1383 A- with suitable wooden block under subframe and press subframe upwards lightly.
- Unscrew hexagon bolts -2- and -3- on both sides.
- Lower subframe slightly with engine and gearbox jack -V.A.G 1383 A-.

**Take care not to damage the underseal or the surfaces of the brake pipes.**

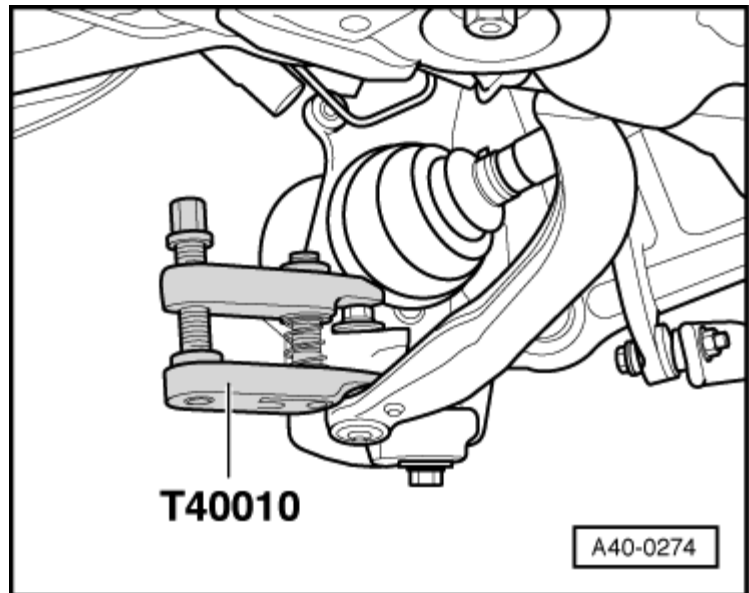

- Remove hexagon bolt -1-.
- Take out guide link.

### Installing



#### Note

Bonded rubber bushes can only be turned to a limited extent. The mountings of the suspension links must therefore only be tightened when the suspension is in the unladen position → [Chapter](#).

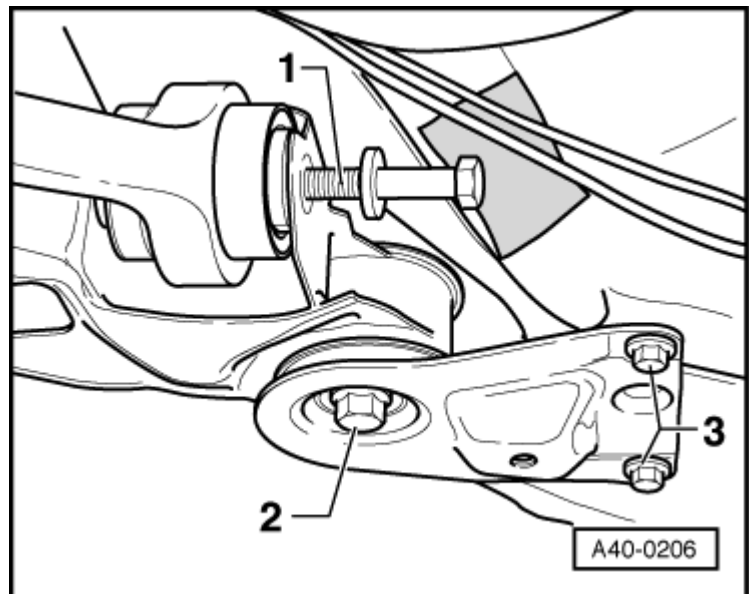

- Tighten nut on joint pin → [Item](#).
- Tighten hexagon bolt -2- → [Item](#).
- Tighten hexagon bolt -3- → [Item](#).
- Secure brake caliper (if detached) → [Brake system; Rep. Gr. 46](#)
- Fit and secure wheel → [Wheels and tyres; Rep. Gr.44](#)

