





Draining and filling cooling system

<p>V.A.G 1274/8</p> 	<p>V.A.G 1274/10</p> 
<p>V.A.G 1306</p> 	<p>V.A.G 1921</p> 
<p>VAS 6096</p> 	<p>T10007</p>  <p style="text-align: right; border: 1px solid black; padding: 2px;">G19-0025</p>

Special tools and workshop equipment required

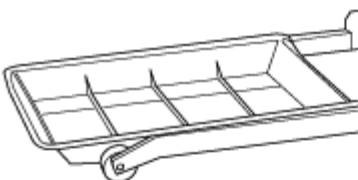
- t Adapter for cooling system tester -V.A.G 1274/8-
- t Pipe for cooling system tester -V.A.G 1274/10-
- t Drip tray for workshop hoist -VAS 6208-
- t Hose clip pliers -V.A.G 1921-
- t Cooling system charge unit -VAS 6096-
- t Refractometer -T10007-

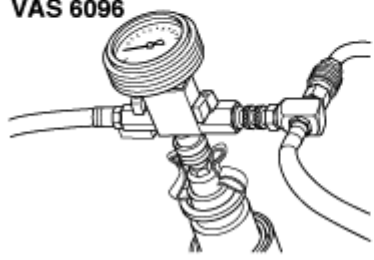
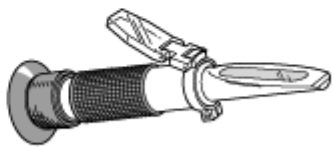
Draining



Note

Collect drained coolant in a clean container for re-use or disposal.



WARNING

Hot steam or hot coolant can escape when expansion tank is opened; cover filler cap with cloth and open carefully.

- Open filler cap on coolant expansion tank.
- Vehicles with auxiliary heater: remove bolts -arrows- securing exhaust pipe for auxiliary/additional heater to noise insulation.

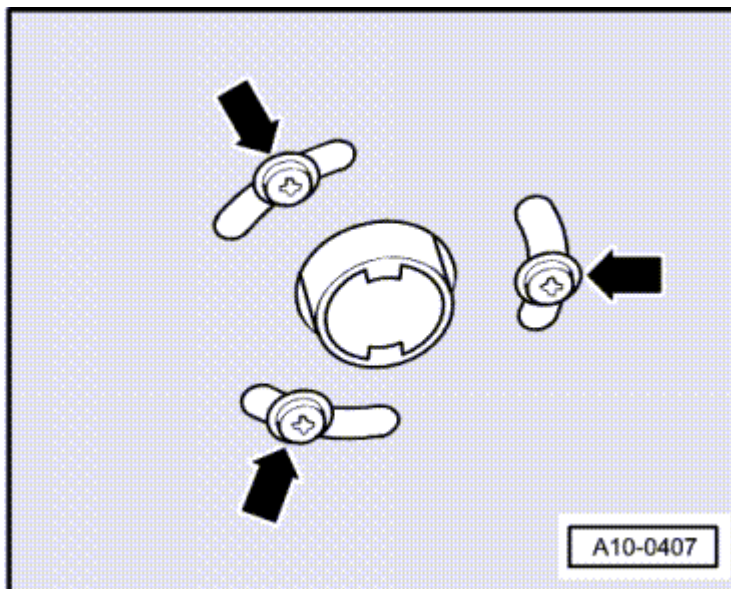

- Release quick-fasteners -1- and -2- and take off front noise insulation. Leave rear noise insulation in position.

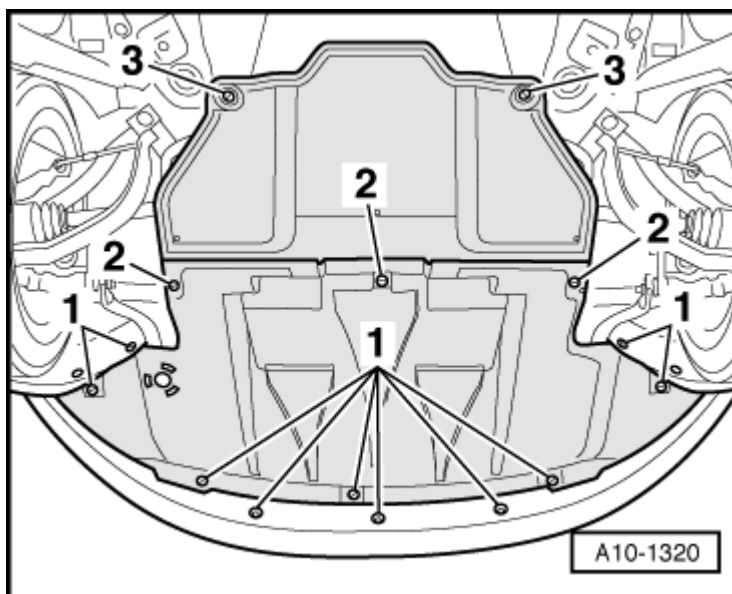

- Place drip tray for workshop hoist -VAS 6208- under engine.

Vehicles with coolant drain plug:

- Unscrew the drain plug -arrow- at coolant hose (bottom left) and drain off coolant.

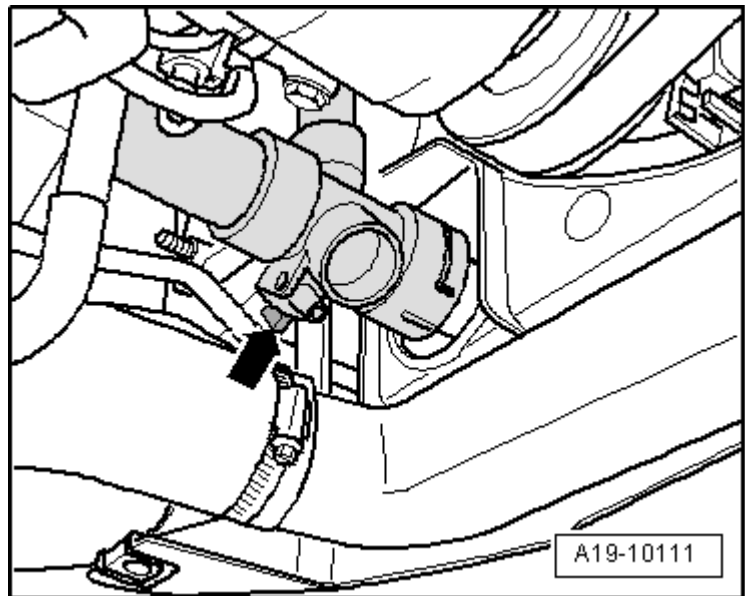

Vehicles without coolant drain plug:

- Pull out retaining clip -1- for coolant temperature sender at radiator outlet -G83- item 2-.
- Pull coolant temperature sender at radiator outlet -G83- out of hose connection and drain off coolant.
- Move wiring for coolant temperature sender at radiator outlet -G83- clear.

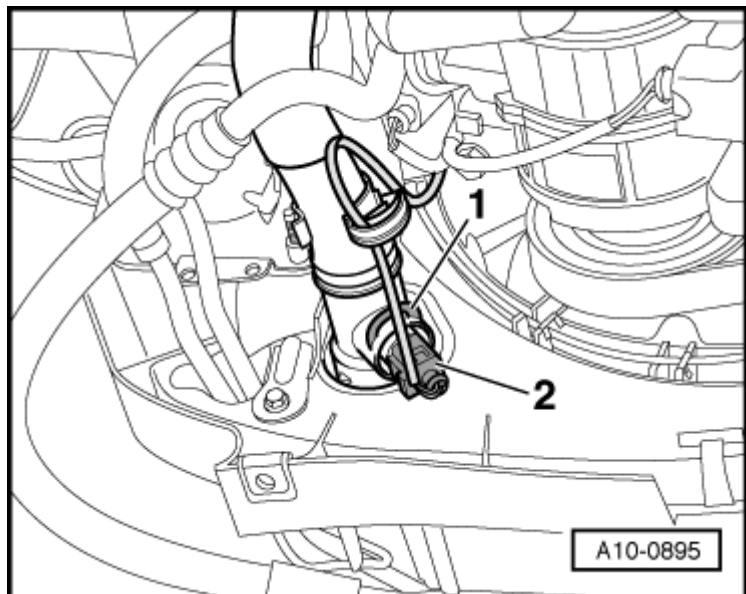

All models:

- Unbolt coolant expansion tank -arrow-.
- Unplug electrical connector for coolant shortage indicator switch -F66- at bottom of expansion tank and move expansion tank to one side with coolant hoses -1- and -2- attached.

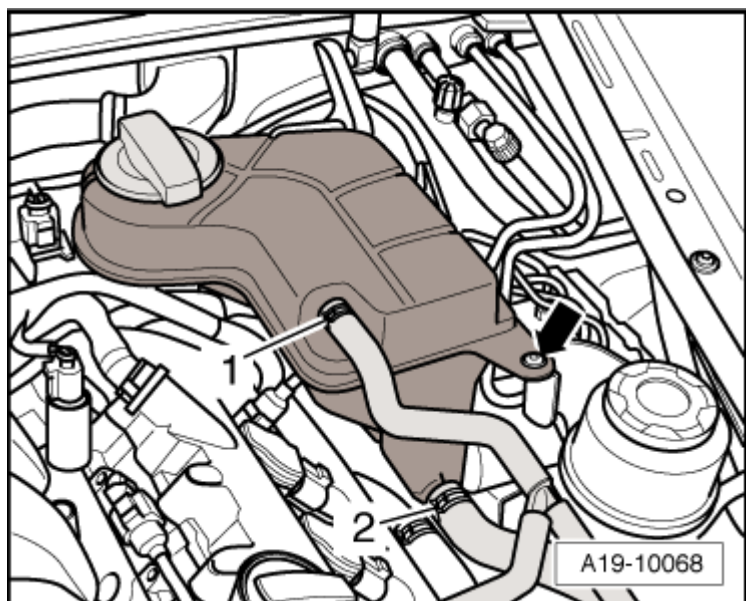

- Also disconnect coolant hose at oil cooler -

arrow-, and drain off remaining coolant.

Filling

Note

- t *The cooling system is filled all year round with a mixture of water and antifreeze/corrosion protection agent.*
- t *It is important to use only coolant additive Plus -G 012 A8F A1- (also designated as "G12+") "meeting specification TL VW 774 F". Other coolant additives could seriously impair in particular the anticorrosion properties. The resulting damage could lead to loss of coolant and consequently to serious engine damage.*
- t *Coolant additive "G12+" may be mixed with additives "G11" and "G12".*
- t *"G12+" and coolant additives marked "Conforming with specification TL VW 774 F" prevent frost and corrosion damage and stop scale from forming. Such additives also raise the boiling point of the coolant. For these reasons the cooling system must be filled all year round with the correct antifreeze and anticorrosion additive.*
- t *Because of its high boiling point, the coolant improves engine reliability under heavy loads, particularly in countries with tropical climates.*
- t *Frost protection is required down to about -25 °C (in countries with arctic climate: down to about -35 °C).*
- t *The coolant concentration must not be reduced by adding water even in warmer seasons and in warmer countries. The antifreeze percentage must be at least 40 %.*
- t *If greater frost protection is required in very cold climates, the proportion of "G12+" can be increased, but only up to 60 % (this gives frost protection to about -40°C). If the antifreeze percentage exceeds 60%, frost protection is reduced again and cooling efficiency is also impaired.*
- t *Only use clean drinking water for mixing coolant.*
- t *If radiator, heat exchanger, cylinder head, cylinder head gasket or cylinder block have been renewed, do not re-use old coolant.*
- t *Contaminated or dirty coolant must not be used again.*
- t *To check frost protection level of coolant additive "G12+" you must use a refractometer -T10007-.*
- t *Secure all hose connections with the correct type of hose clips (same as original equipment) → [Parts catalogue](#).*

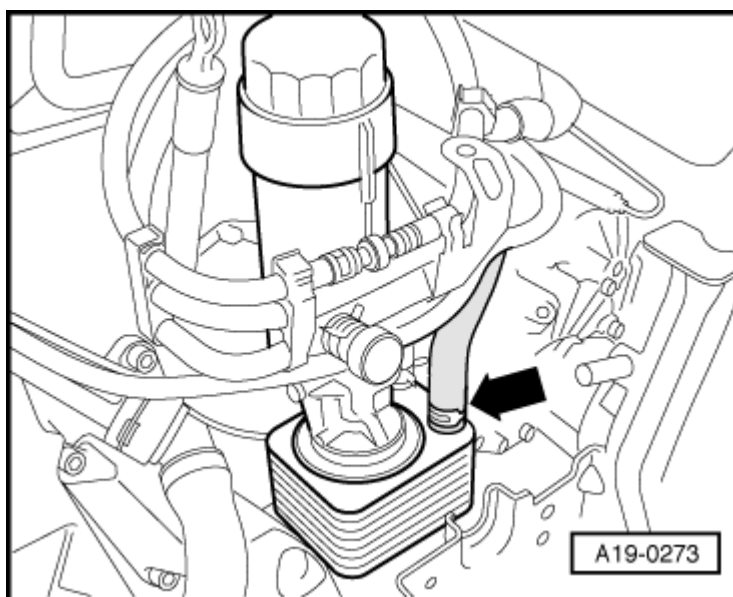

Procedure**Vehicles with coolant drain plug:**

- Close drain plug -arrow-.

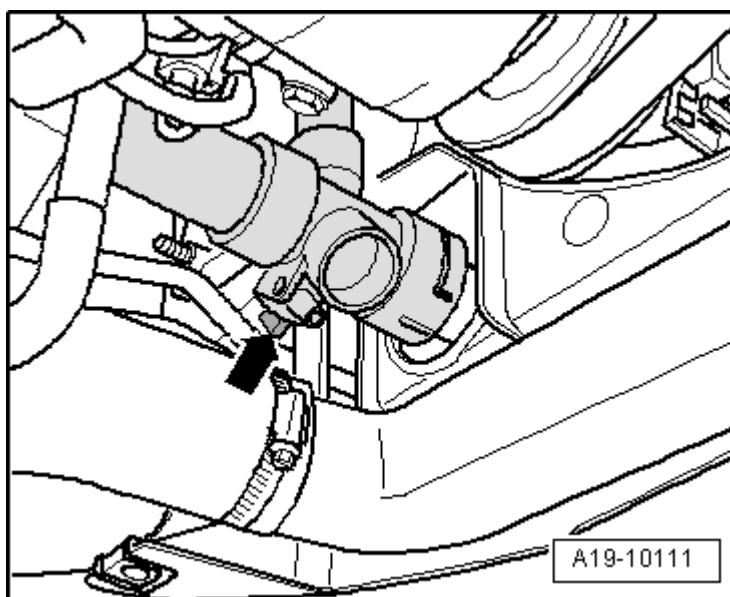
**Vehicles without coolant drain plug:**

- Insert coolant temperature sender at radiator outlet -G83--item 2- with new O-ring into connection and locate with retaining clip -1-.

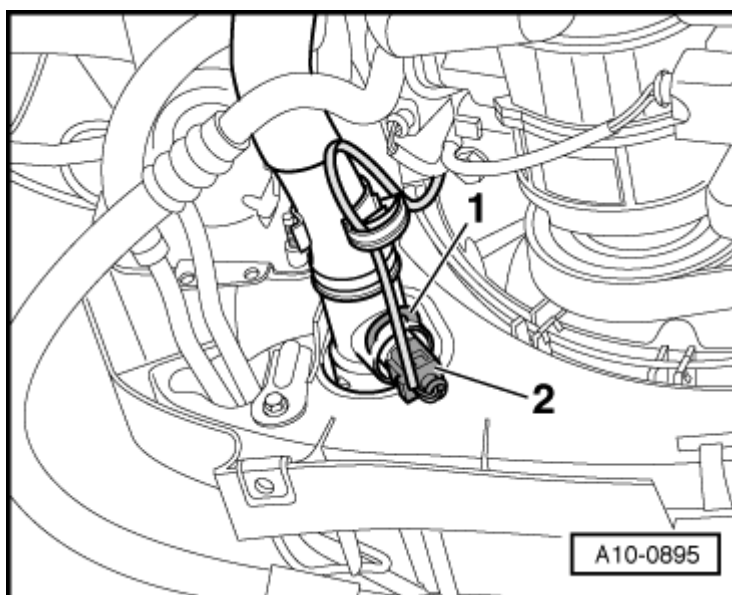
**All models:**

- Connect coolant hose to oil cooler -arrow-.

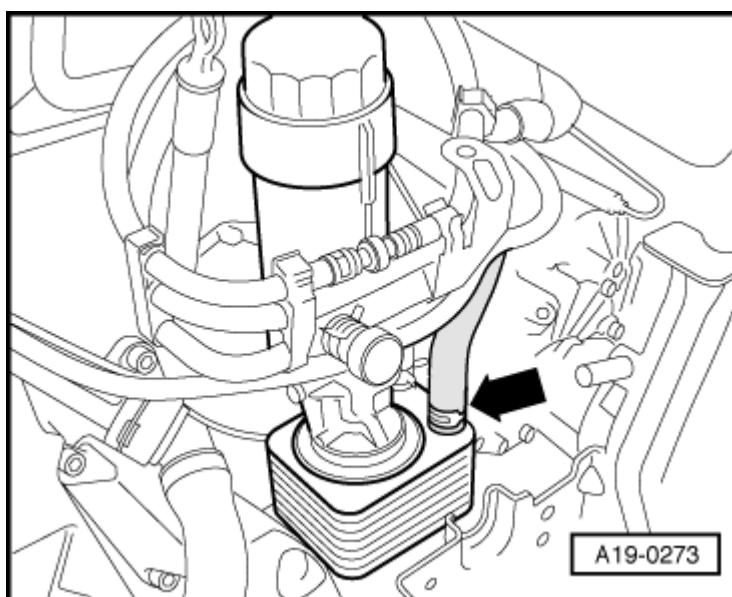

- Fill reservoir -VAS 6096/1- with at least 10 litres of premixed coolant (according to

recommended ratio):

- 1 "G12+" (40 %) and water (60 %) for frost protection to -25 °C
- 1 "G12+" (50 %) and water (50 %) for frost protection to -35 °C
- 1 "G12+" (60 %) and water (40 %) for frost protection to -40 °C
- Screw adapter for cooling system tester - V.A.G 1274/8- onto coolant expansion tank.
- Attach cooling system charge unit - VAS 6096- to adapter -V.A.G 1274/8-.
- Feed vent hose -1- into a small container - 2-. (The vented air draws along a small amount of coolant, which should be collected.)
- Close both valves -A- and -B- (turn lever perpendicular to direction of flow).
- Connect hose -3- to compressed air.
- 1 Pressure: 6 ... 10 bar.

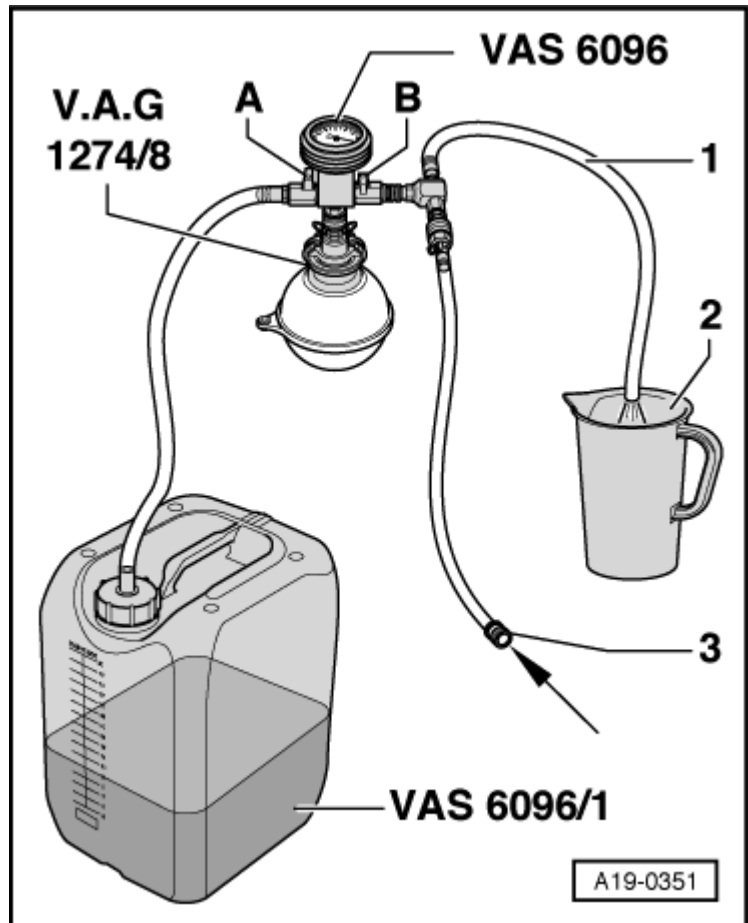

- Open valve -B- (turn lever in direction of flow).

The suction jet pump generates a partial vacuum in the cooling system.

- 1 The needle on the gauge must move into the green zone.
- Also briefly open valve -A- (turn lever in direction of flow) so that hose on charge unit -VAS 6096/1- can fill with coolant.
- Close valve -A- again.
- Leave valve -B- open for another 2 minutes.
- 1 The suction jet pump will continue generating a vacuum in the cooling system.
- 1 The needle on the gauge must remain in the green zone.
- Close valve -B-.
- 1 The needle on the gauge should stop in the green zone. The vacuum level in the cooling system is then sufficient for subsequent filling.

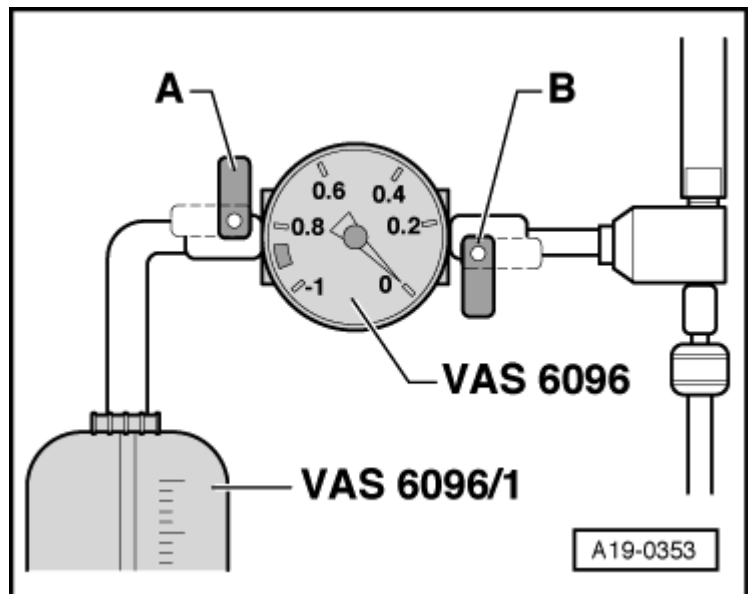

If the needle does not reach the green area, repeat the process.

If the vacuum level drops, there is a leak in the cooling system.

- Detach the compressed air hose.
- Open valve -A-.

The partial vacuum in the cooling system causes the coolant to be drawn up out of the reservoir; the cooling system is then filled.

- Detach cooling system charge unit -VAS 6096- from expansion tank.
- Fit pipe for cooling system tester -V.A.G 1274/10- onto adapter for cooling system tester -V.A.G 1274/8-.

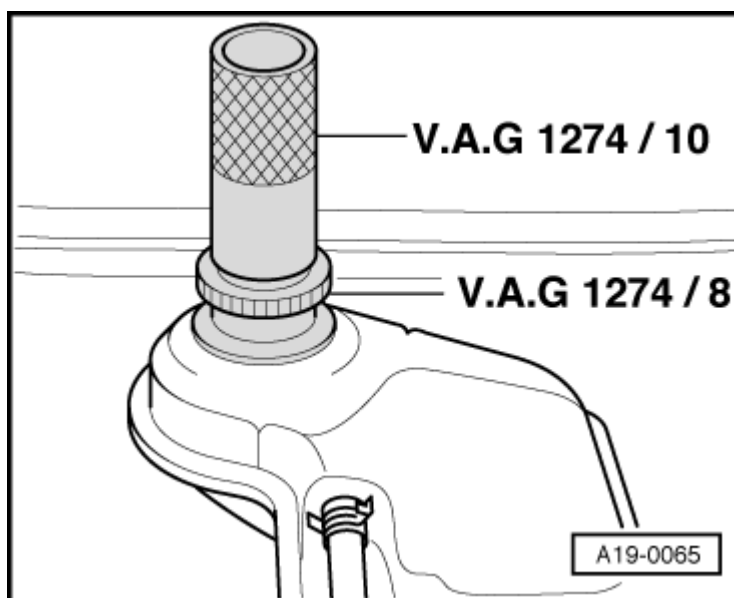

- If fitted, detach rubber seal from plenum chamber cover in direction of -arrow-.
- Detach plenum chamber cover -1- to front.

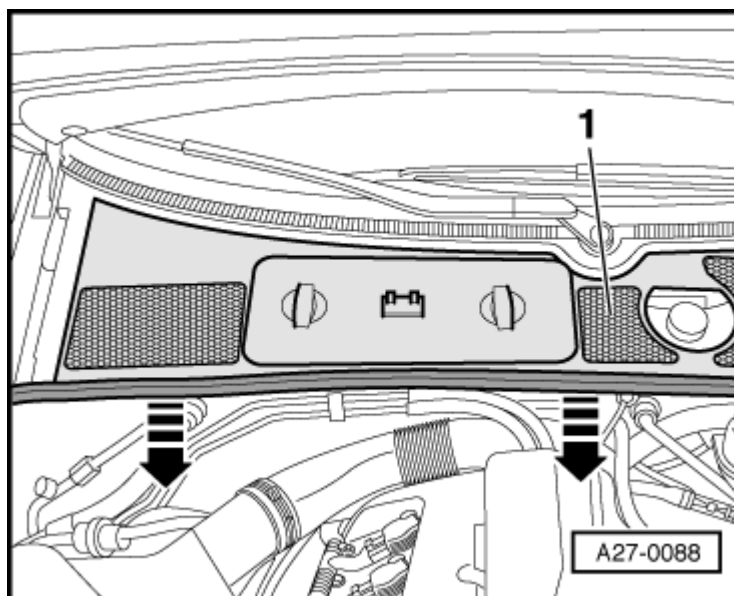

- Loosen coolant hose going to heat exchanger and pull back hose until bleeder hole in hose -arrow- is no longer blocked by the connection.
- Fill up with coolant until it flows out at bleeder hole in coolant hose.
- Push coolant hose onto connection and tighten using hose clip.

- On vehicles with auxiliary heater, switch heater on (for about 30 seconds) and then off again.
- Tighten filler cap on expansion tank.
- Start the engine.
- Set heater/air conditioner to "HI".
- Run the engine for 3 minutes at 2000 rpm.
- Allow the engine to run at idling speed until the two large coolant hoses at main radiator become warm.
- Run the engine for 1 minute at 2000 rpm.
- Switch off ignition and allow to cool down.

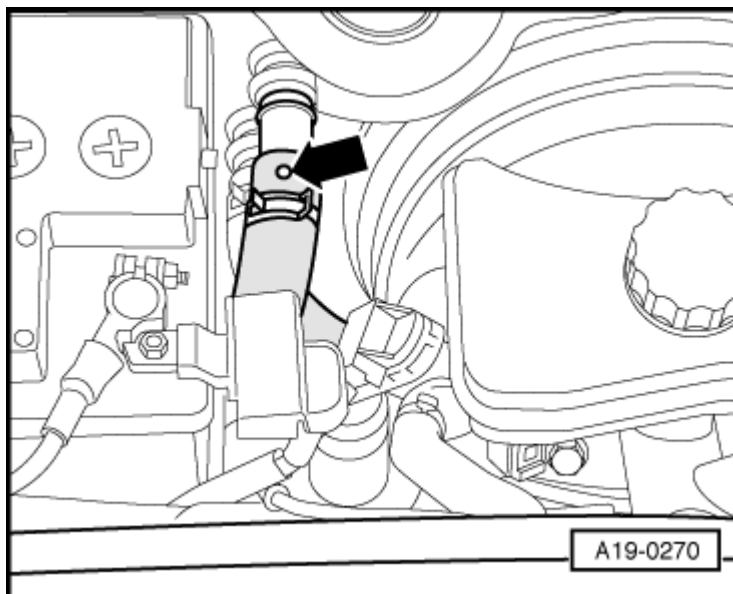

- Check coolant level.
 - 1 The coolant level must be at the MAX marking when the engine is cold.
 - 1 The coolant level can be above the MAX marking when the engine is warm.

